

LOW HEADROOM FRONT TORSION SPRING

Supplemental insert

This supplemental installation instruction is to be used as a supplement to the main Installation Instruction and Owner's Manual provided with the door. The instructions included in this document are ONLY those which deviate from the standard installation. All WARNINGS and CAUTIONS listed in the main manual are applicable to this supplemental instruction as well.

www.Wayne-Dalton.com

INSTALLATION

NOTE: Standard Lift Bottom Corner Brackets are used with this type of Low Headroom Counterbalance.

1

Fully Adjustable jamb brackets

NOTE: If quick install jamb brackets were installed, skip this step and continue with horizontal track installation. If not, complete this step.

The bottom jamb bracket is always the shortest bracket included with your door. It does not necessarily mean the "short" (ST-0) jamb bracket. If three jamb brackets are included with your door, the center bracket is the middle bracket in height. The top jamb bracket is the tallest bracket included, as shown in **FIG. 1.1**.

NOTE: Doors over 7' 3" high get (3) jamb brackets for each side.

To attach the jamb bracket(s), locate the slot pattern of the vertical track, as shown in **FIG. 1.2**.

Align slot in jamb bracket with the slot pattern in the vertical track. Secure jamb bracket using (1) 1/4" - 20 x 9/16" track bolt and 1/4" - 20 flange hex nut, as shown in **FIG. 1.2**.

NOTE: If a third jamb bracket is required, equally space the distance between the bottom jamb bracket, the two center jamb brackets and the flagangle.

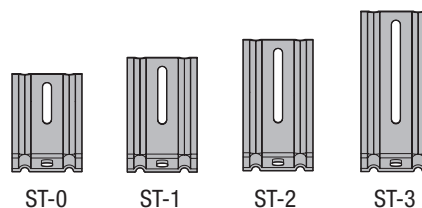

FIG. 1.1

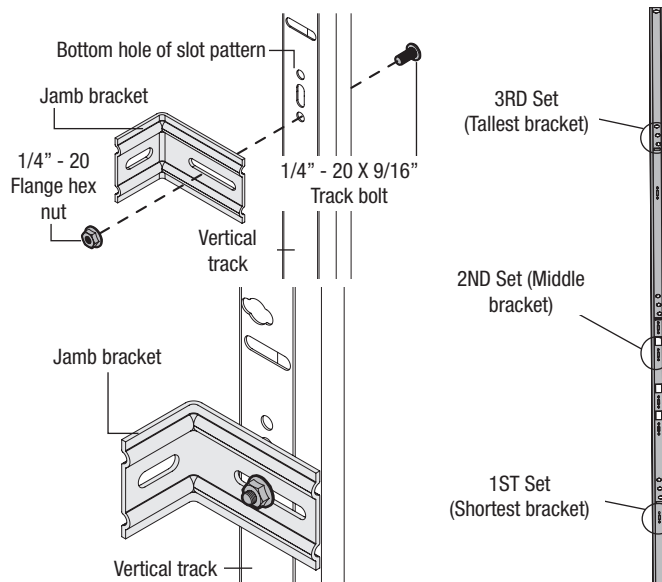

FIG. 1.2

Windload Jamb Brackets

NOTE: If you do not have windload jamb brackets, skip this step and complete step horizontal track installation on page 4.

NOTE: Windload specification 0356 only uses the (QI) jamb bracket schedule.

NOTE: The following (JB) denotes a slotted jamb bracket.

Measure the length of the vertical track. Using the windload jamb bracket schedule, determine the placement of the jamb brackets for your door height and track type.

Loosely fasten the (JB) jamb bracket to the track with a 1/4"-20 x 9/16" track bolt and 1/4"-20 flange hex nut, as shown in **FIG. 2.1** and **FIG. 2.2**.

WINDLOAD (JB) JAMB BRACKET SCHEDULE

DOOR HEIGHT	NO. OF SECTIONS	NO. OF JAMB BRACKETS (EACH JAMB)	TRACK TYPE	LOCATION OF CENTER LINE OF JAMB BRACKETS MEASURED FROM BOTTOM OF TRACK (ALL DIMENSIONS ± 2")
WINDLOAD SPECIFICATION 0228				
7'-0" or Less	4	1	Q.I.	2" (JB), 63" (JB)
			F.A.T	2" (JB), 42" (JB), 63 1/4" (JB)
7'-1" to 8'-0"	4 or 5	1	Q.I.	2" (JB), 34" (JB)
			F.A.T	2" (JB), 10" (JB), 29 3/4" (JB), 48" (JB), 66" (JB)
WINDLOAD SPECIFICATION 0229, 0600, & 0602				
7'-0" or Less	4	2	Q.I.	25 1/2" (JB), 63" (JB)
			F.A.T	10" (JB), 21 3/4" (JB), 42" (JB), 63 1/4" (JB)
7'-1" to 8'-0"	4 or 5	2	Q.I.	23" (JB), 34" (JB)
			F.A.T	10" (JB), 21 3/4" (JB), 29 3/4" (JB), 48" (JB), 66" (JB)
WINDLOAD SPECIFICATION 0230, 0232, 0233, 0234, 0601, 0603, 0607, & 0608				
7'-0" or Less	4	4	Q.I.	2" (JB), 25-1/2" (JB), 34" (JB), 63" (JB)
			F.A.T	2" (JB), 10" (JB), 21 3/4" (JB), 29 3/4" (JB), 42" (JB), 63 1/4" (JB)
7'-1" to 8'-0"	4 or 5	5	Q.I.	2" (JB), 23" (JB), 34" (JB), 58" (JB), 75" (JB)
			F.A.T	2" (JB), 10" (JB), 21 3/4" (JB), 29 3/4" (JB), 48" (JB), 57 1/4" (JB), 66" (JB), 75 1/2" (JB)
WINDLOAD SPECIFICATION 0605				
7'-0" or Less	4	4	Q.I.	2" (JB), 23" (JB), 34" (JB), 58" (JB), 75" (JB)
7'-1" to 8'-0"	4 or 5	5	F.A.T	2" (JB), 10" (JB), 21 3/4" (JB), 29 3/4" (JB), 48" (JB), 57 1/4" (JB), 66" (JB), 75 1/2" (JB)

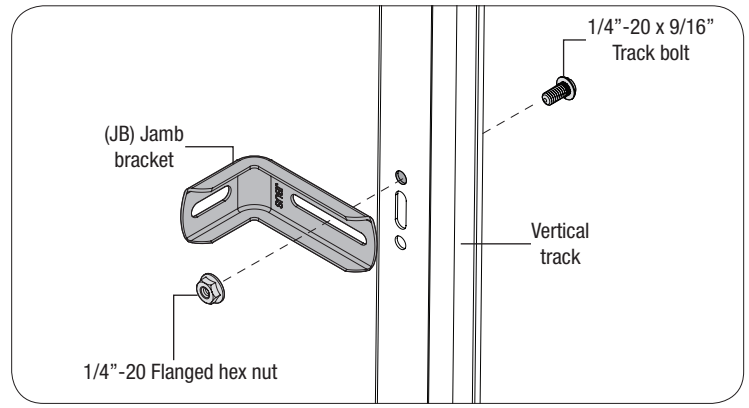

FIG. 2.1

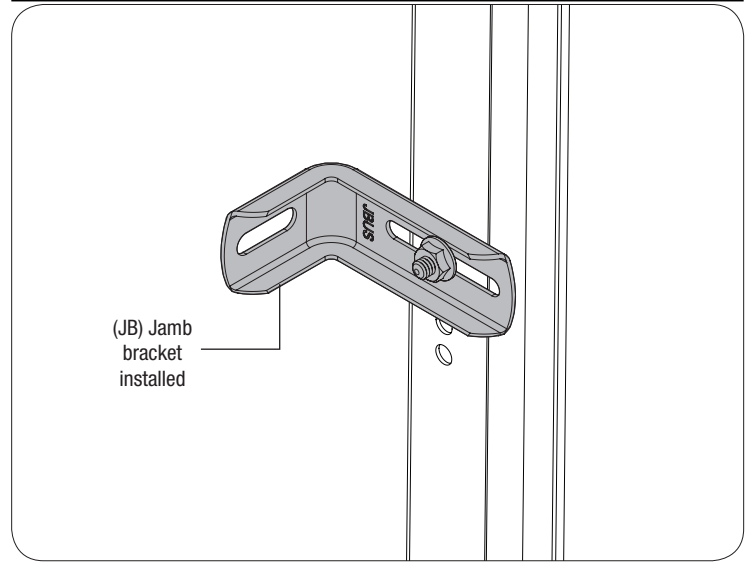

FIG. 2.2

Low Headroom Top Fixture Installation

Identify the low-headroom top fixtures provided with your door (A, B, C, D or E). Push the top section of door out against the jamb until the top section is parallel with the other sections of the door. Starting with the left hand side, align the edge of top fixture with the edge of section.

NOTE: When installing the top fixtures, the top section must be vertically aligned with the rest of the sections from the side view. If needed reposition top fixture(s) to achieve vertical alignment.

FOR LOW HEADROOM TOP BRACKET (A) OR (B):

If applicable, remove, but retain (2-4) 1/4" - 14 x 7/8" self drilling screws from the right side of the strut, allowing enough room to slide the top fixture between the section and the strut. Secure the low headroom top fixture to the top section by placing one 1/4" - 20 x 11/16" self drilling screw through the lower slot of top fixture. Adjust the low headroom top fixture if necessary.

For Models 8000/8100/8200: Secure two more 1/4" - 20 x 11/16" self drilling screws through the top holes, as shown in FIG. 3.1.

For Models 6600/8300/8500: Secure the top fixture and strut (if applicable) to the top section with (3) 1/4" - 20 x 7/8" self drilling screws through the upper and lower slots of the top fixture. Finish re-attaching the strut (if applicable) using the 1/4" - 20 x 7/8" self drilling screws removed previously, as shown in FIG. 3.2.

Repeat the same process for the other side.

FOR LOW HEADROOM TOP BRACKET (C) OR (D):

NOTE: The LHR top fixture comes pre-assembled, as shown in FIG. 3.4 or FIG. 3.5. Locate the edge of the top section and seat the top fixture on male part of the top section, as shown in FIG. 3.3.

Attach the top fixture to the top section (C):

1. Attach one 1/4" - 20 x 11/16" self-drilling screw to the top fixture assembly.
2. Attach two 1/4" - 20 x 11/16" self-drilling screws to the top fixture assembly.
3. Attach two #12 x 1/2" phillips head screws on the opposite side of top fixture assembly.

Insert a short stem track roller into the top fixture slide, as shown in FIG. 3.4. Repeat the same process for the other side.

Attach the top bracket to the top section (D):

1. Attach one 1/4" - 14 x 5/8" self-tapping screw to the top fixture assembly.
2. Attach two 1/4" - 20 x 11/16" self-drilling screws to the top fixture assembly.
3. Attach two #12 x 1/2" phillips head screws on the opposite side of top fixture assembly.

Insert a roller into the top fixture, as shown in FIG. 3.5. Repeat the same process for the other side.

REVERSING THE TOP SLIDE (C) OR (D), IF NEEDED:

NOTE: Depending on your application, you may need to reverse the top fixture slide for more adjustment, if needed, prior to securing it to the top fixture base. Remove the top fixture slide by removing the two 1/4" - 20 x 5/8" carriage bolts, two retention washers and two 1/4" - 20 flanged hex nuts. Flip the top fixture slide in the opposite direction. Loosely fasten the top fixture slide to the fixture using two 1/4" - 20 x 5/8" carriage bolts, two retention washers and two 1/4" - 20 flanged hex nuts, as shown in FIG. 3.6 or FIG. 3.7.

NOTE: The retention washers must be fully seated against the top fixture base to ensure the anti-twist feature on the top fixture slide engages in the slotted hole in the top fixture base.

FOR LOW HEADROOM HORIZONTAL TRACK (E):

NOTE: This is a traditional low headroom windload top fixture.

Vertically align the flat portion of top fixture slide with the endcap and strut at the top of top section. Fasten top fixture slide using (2) 1/4" - 14 x 7/8" self drilling screws, as shown in FIG. 3.8. Repeat the same process for the other side.

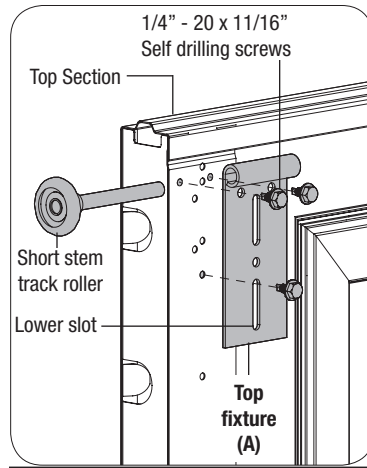

FIG. 3.1

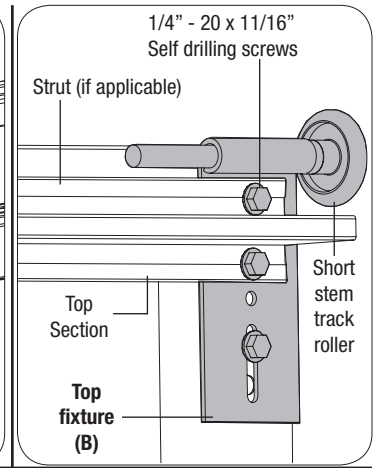

FIG. 3.2

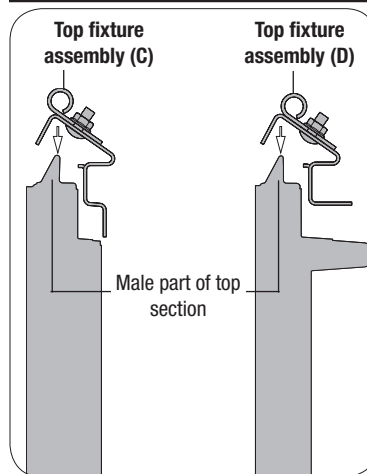

FIG. 3.3

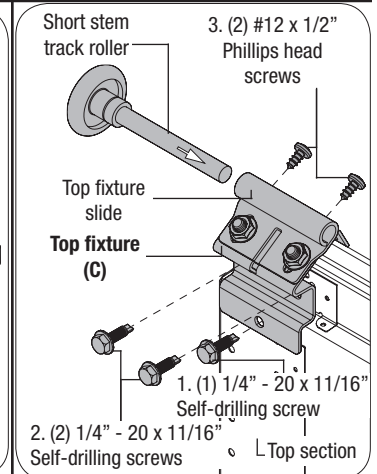

FIG. 3.4

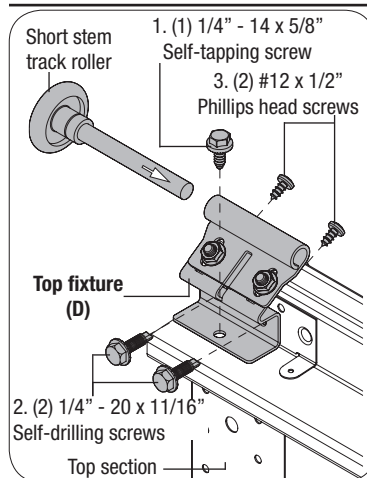

FIG. 3.5

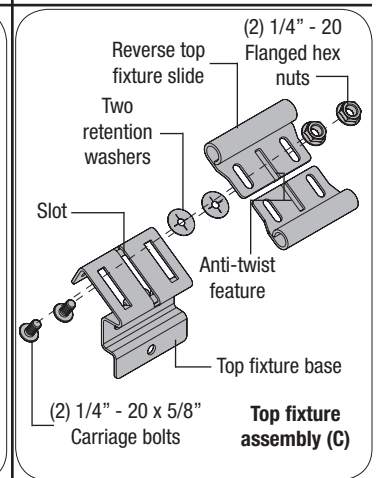

FIG. 3.6

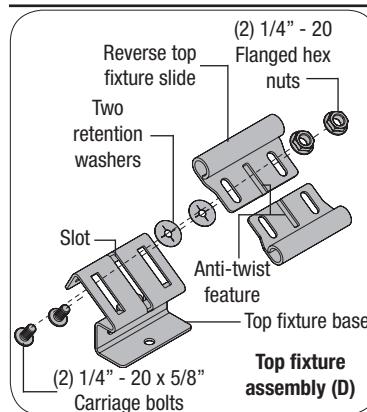

FIG. 3.7

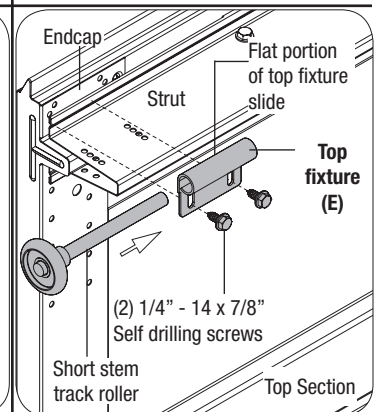

FIG. 3.8

WARNING

DO NOT RAISE DOOR UNTIL HORIZONTAL TRACKS ARE SECURED AT REAR, AS OUTLINED IN REAR SUPPORT INSTALLATION, OR DOOR COULD FALL FROM OVERHEAD POSITION CAUSING SEVERE OR FATAL INJURY.

4

Horizontal Track and End Bearing Bracket Installation

Place the horizontal tracks over the top of the previously installed vertical tracks. Attach the bottom of the lower curve to the flagangle using (1) stud plate or (2) 1/4-20 track bolts and nuts.

Level horizontal track and secure the upper curve to the flagangle using (1) 1/4-20 x 9/16" track bolt, 3/8" flat washer and flanged hex nut. Secure 1" x 4" x 23" horizontal angle (if supplied) to the flag angle with (1) 3/8 x 3/4" truss head bolt and nut, as shown in FIG. 4.

NOTE: Check the clearance between the upper curve and the jamb. The clearance must be a minimum of 3/4", as shown in FIG. 4.2. If it is less than 3/4" trim the top curve with a hacksaw to ensure counterbalance cable clearance.

Place the left hand end bearing fixtures above the flagangles. Attach the fixtures to the flagangle with (1) 3/8 x 3/4" truss head bolt and nut, and to the jamb with (2) 5/16" x 1-5/8" lag bolts, as shown in FIG. 4.1 and 4.3.

IMPORTANT! MAINTAIN SPACING SPECIFIED BETWEEN END BEARING FIXTURES AND FLAG ANGLES, AS SHOWN IN FIG. 4.3 TO ENSURE PROPER CLEARANCE OF COUNTERBALANCE.

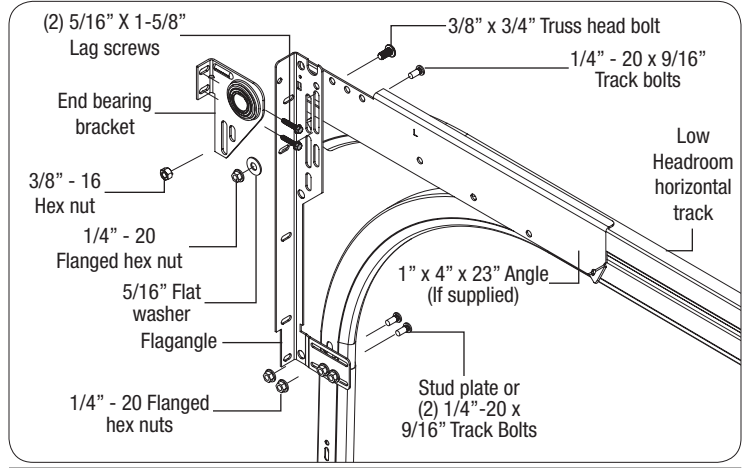

FIGURE 4.1

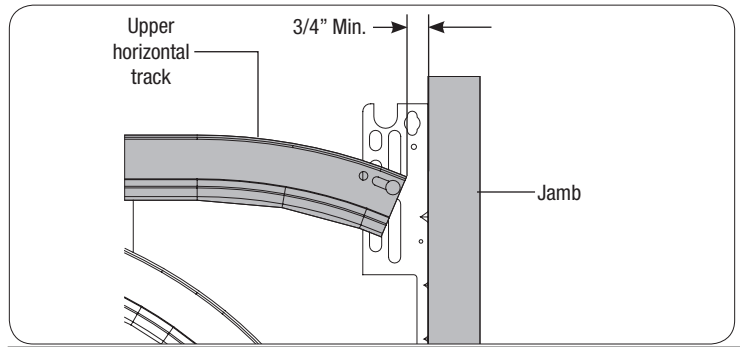

FIGURE 4.2

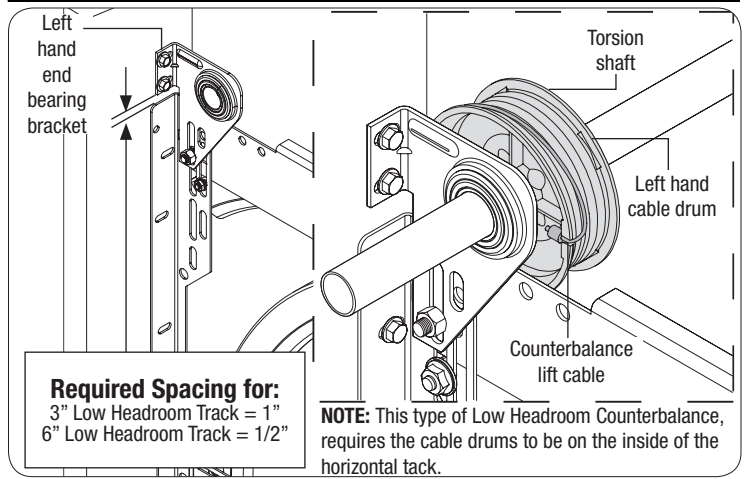

FIGURE 4.3

5

Rear Support Installation

Clamp a pair of locking pliers onto the straight leg of each horizontal track 30"-35" from the jamb. Raise the door until the top roller hits the locking pliers previously installed and clamp a pair of locking pliers, below the bottom rollers, onto the straight leg of both vertical tracks to prevent the door from falling. Move the horizontal track until it is parallel with the edge of the door and level, then secure the lower horizontal track to the rear support drop angle using a 5/16"-18 x 1-1/4" bolt and nut. Drill a 5/16" hole through the top horizontal track and secure with a 5/16"-18 x 1-1/4" bolt and nut to be used as a roller stop, as shown in FIG. 5.1. Lower the door into the opening to finish the installation.

NOTE: rear support material supplied by others (lateral brace must always be used to prevent swaying of horizontal track).

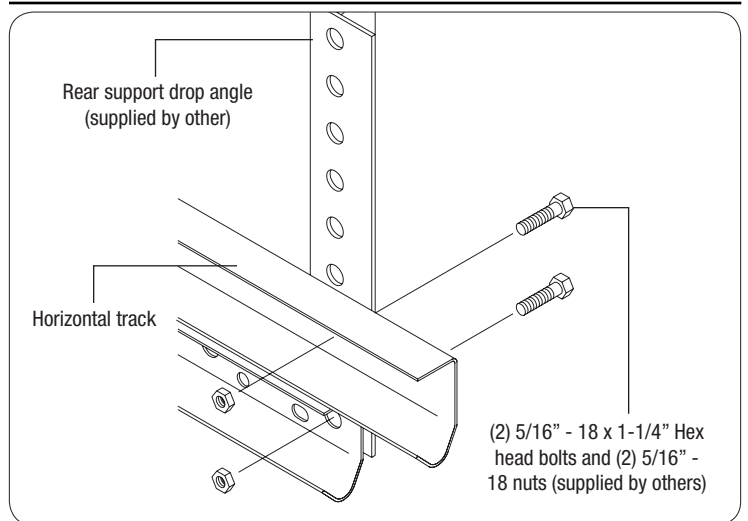

FIG. 5.1