

Drawbar Operator Bracket

For Slab Section Models: 8300/8500, 5150/5155, 5200/5255

Supplemental Insert

This supplemental installation instruction is to be used as a supplement to the main Installation Instruction and Owner's Manual provided with the door. The instructions included in this document are only those which deviate from the standard installation. All warnings and cautions listed in the main manual are applicable to this supplemental instruction as well.

www.wayne-dalton.com

1

Drawbar Operator Bracket

Tools Needed:

- Level
- Power Drill
- 7/16" Socket Driver
- Tape Measure
- 1/2" Socket
- Ratchet wrench
- 1/2" Wrenches

WARNING

POTENTIAL DAMAGE TO YOUR TOP SECTION MAY OCCUR IF INSTALLER DOES NOT FOLLOW THESE OPERATOR BRACKET INSTRUCTIONS CLOSELY. IF THE INSIDE PORTION OF YOUR TOP SECTION HAS PINSTRIPES, IT IS VERY IMPORTANT TO POSITION AND INSTALL THE OPERATOR BRACKET ON THE TOP SECTION, AS SHOWN. THIS WILL ENSURE THE OPERATOR BRACKET FASTENERS (SUPPLIED BY OTHERS) BEING USED ARE GOING THROUGH BOTH THE BACKUP PLATES INSIDE THE TOP SECTION. IT IS EQUALLY IMPORTANT FOR THE INSTALLER TO NEVER INSTALL THE OPERATOR BRACKET UPSIDE DOWN. NOT FOLLOWING THESE INSTRUCTIONS CAN RESULT IN OPERATOR BRACKET BEING PULLED OFF THE TOP SECTION.

IMPORTANT: WHEN INSTALLING A TROLLEY TYPE OPERATOR ON THIS DOOR, A WAYNE-DALTON TROLLEY BRACKET MUST BE SECURELY ATTACHED TO THE TOP SECTION WHEN ATTACHING A TROLLEY TYPE OPERATOR, AS LONG AS THE INSTALLATION OF THE OPERATOR IS ACCORDING TO INSTALLATION INSTRUCTIONS AND OWNER'S MANUAL AND FORCE SETTINGS ARE ADJUSTED PROPERLY, IT IS NOT NECESSARY TO INSTALL ADDITIONAL TOP SECTION REINFORCEMENT FOR SQUARE, LEVEL INSTALLATION. HOWEVER, IF THE BUILDING FRAMING DOES NOT ENABLE SQUARE, LEVEL INSTALLATION, IT MAY BE NECESSARY TO FURTHER REINFORCE THE TOP SECTION.

NOTE: For retro fit applications, the operator bracket must be aligned with an existing operator.

Place the bottom half inside the top half and flush against the inside surface of the top section. Adjust both the top and bottom halves out as far apart as possible on the section surface. Secure the bottom half and the top half together using (4) 5/16"-18 x 1/2" carriage bolts and (4) 5/16"-18 flange hex nuts.

NOTE: Install the 5/16"-18 x 1/2" carriage bolts and the 5/16"-18 flange hex nuts as far apart as possible, prior to securing both top and bottom halves together.

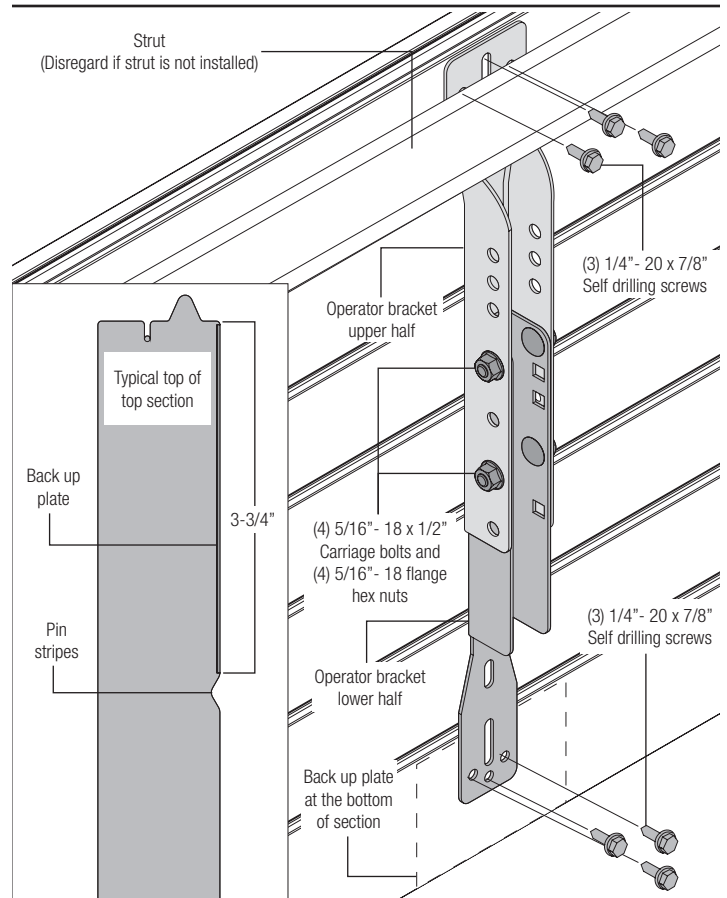
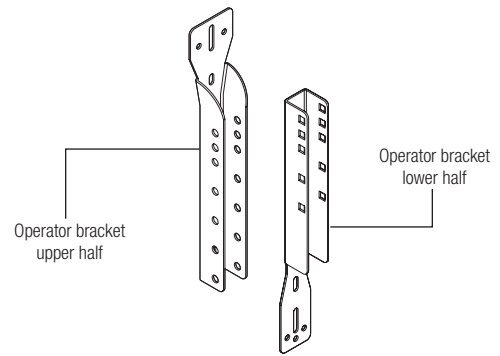

IF STRUT IS INSTALLED

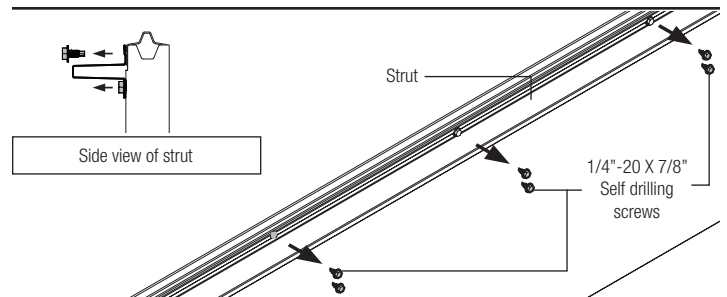

Drawbar Operator Bracket Continued...

Now, locate the center of the top section and align the center of the holes in the adjustable operator bracket assembly with the top section center line. Align the adjustable operator bracket assembly vertically.

NOTE: For retro fit applications, the adjustable operator bracket must be aligned with an existing operator.

Slide the top half of the operator bracket under the strut, keeping the operator bracket aligned with the center line. Remove the strut's screws if necessary and attach to the top section (through strut if necessary) using (3) 1/4" - 20 x 7/8" self drilling screws.

NOTE: If your door lacks a strut on the top section, ignore the previous paragraph.

Attach the bottom half of the operator bracket to the section surface using (3) 1/4" - 20 x 7/8" self drilling screws.

NOTE: When attaching operator bracket to top section with strut, apply additional pressure to thread into the strut.

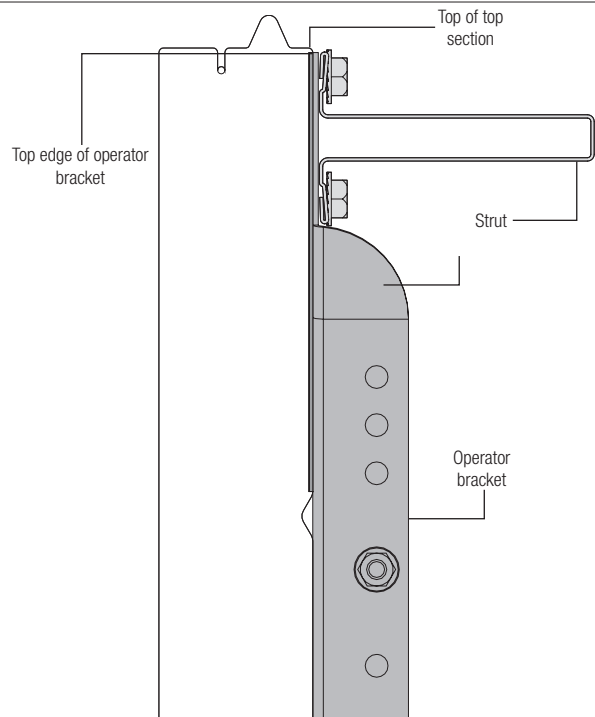

Side view of strut with Operator bracket installed

2

Door Arm Attachment

Tools Needed: NONE
Align hole in the appropriate arm with holes in operator bracket tabs. Insert clevis pin, making sure hole in clevis pin is outside of second tab of operator bracket. Insert cotter ring into clevis pin hole to ensure it will secure assembly.

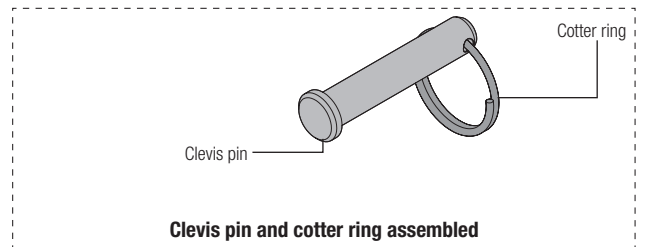
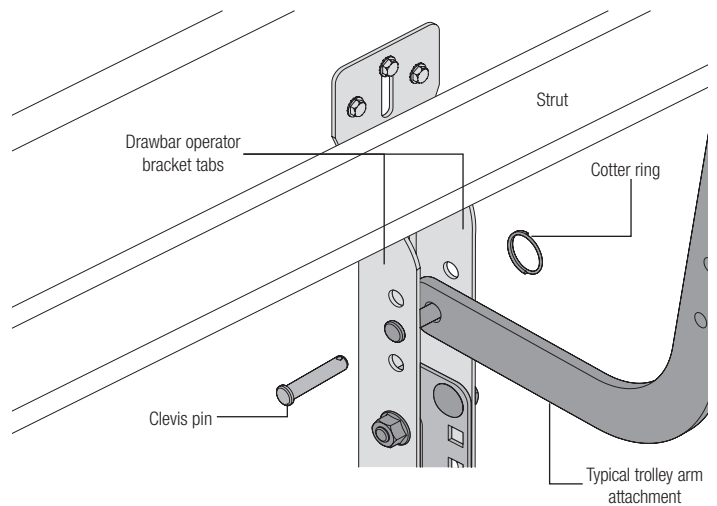

Clevis pin and cotter ring assembled