



# WayneMark™ & WayneWood™ Fully Adjustable Track Installation Instructions Insert

Use this insert in conjunction with the installation manual provided with the door. Follow the corresponding steps in this insert with the steps in the installation manual. Riveted track for WayneMark and WayneWood has been replaced by fully adjustable track.

## BEFORE TRACK INSTALLATION

Vinyl weather seal must be installed prior to door installation. Attach the weather seal to the door jamb 1/8" to 1/4" past door jamb (See **Figure 1**).

Follow the corresponding steps in the main installation manual for centering and leveling the bottom section.

**NOTE:** When shims are used to level the door, the track will also need to be shimmed to the same level.

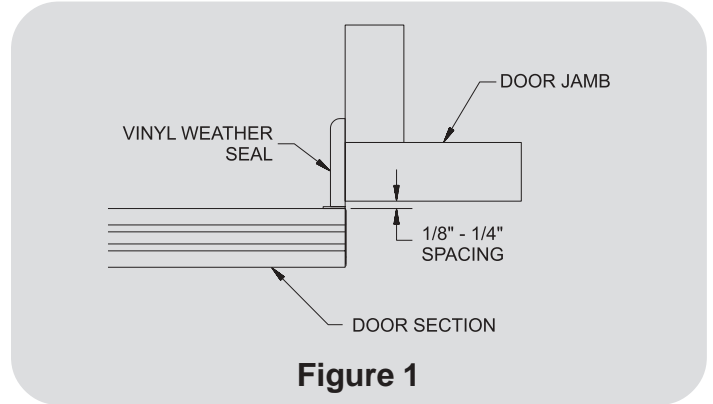

**Figure 1**

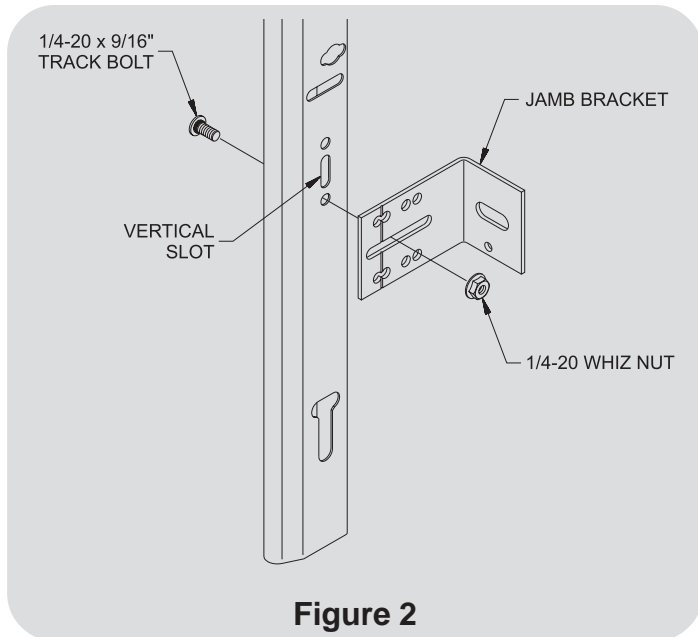

**Figure 2**

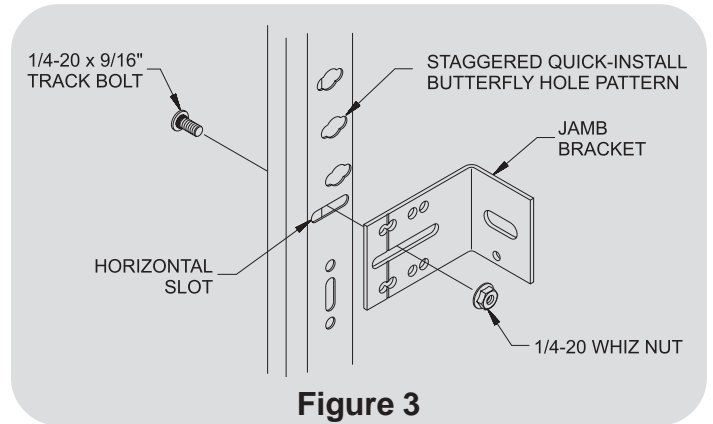

**Figure 3**

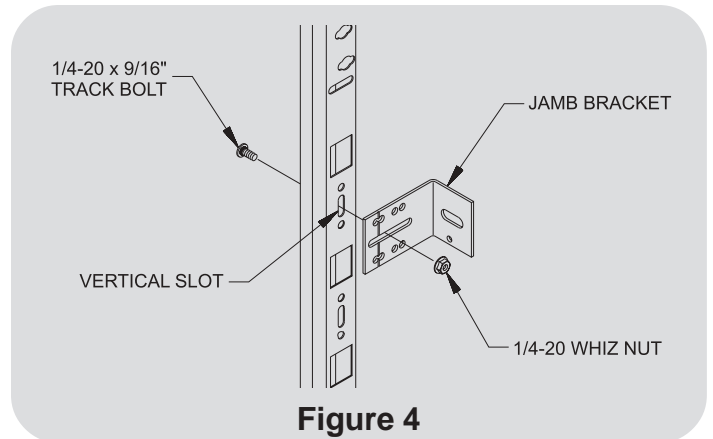

**Figure 4**

## INSTALLING BOTTOM JAMB BRACKET

Align slot of jamb bracket with the lower hole in the bottom vertical hole/slot cluster (see **Figure 2**). Hand tighten jamb bracket to vertical track using a 1/4-20 x 9/16" track bolt and whiz nut.

## INSTALLING TOP JAMB BRACKET

Locate the highest Quick-Install butterfly hole pattern on the vertical track and align jamb bracket slot with the horizontal slot (see **Figure 3**). Hand tighten using a 1/4-20 x 9/16" track bolt and nut.

## INSTALLING CENTER JAMB BRACKET (DOOR HEIGHTS 7'-3" TO 8'-0")

An additional jamb bracket will be needed on door heights 7'-3" to 8'-0". Align slot of jamb bracket with the vertical slot closest to the middle of the vertical track, spanning midway between the upper and lower jamb brackets. Hand tighten, using a 1/4-20 x 9/16" track bolt and whiz nut.

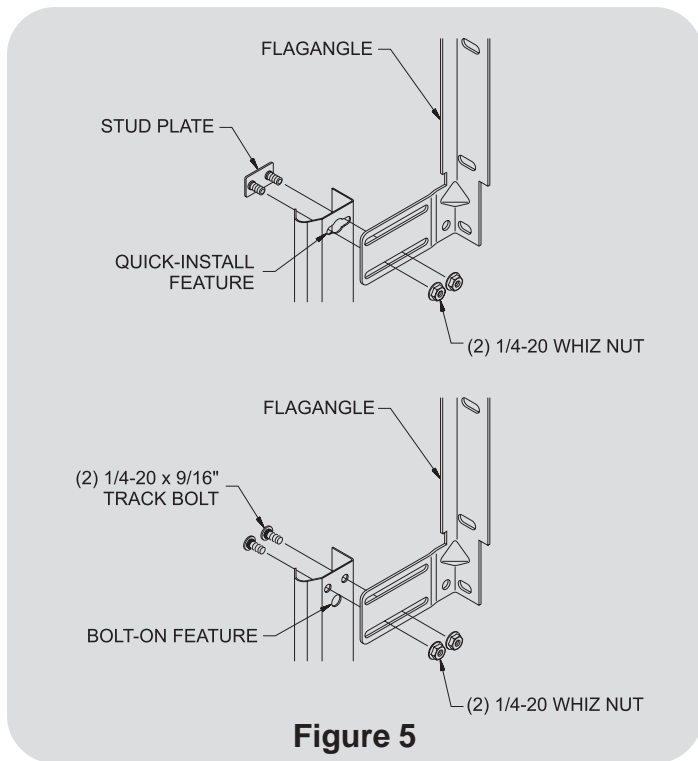

**Figure 5**

## ATTACHING FLAGANGLE TO VERTICAL TRACK

**Quick-Install Track System** - Hand tighten the flagangle to the vertical track using a stud plate and (2) 1/4 - 20 whiz nuts.

**Bolt-On Track System** - Hand tighten the flagangle to the vertical track using (2) 1/4 - 20 x 9/16" track bolts and whiz nuts.

## INSTALLING THE VERTICAL TRACK

Slide vertical track assembly over rollers in the bottom door section. Shim track if applicable. Temporarily attach flagangle to the door jamb using (2) 5/16 x 1-5/8" lag screws. Temporarily fasten each jamb bracket to the door jamb with (1) 5/16 x 1-5/8" lag screw. Repeat for other side. Continue installing the remaining door sections.

## SPACING VERTICAL TRACK

After all sections are installed, check for alignment. Ensure that the edge of the door sections are aligned and each section is vertically aligned against the weather seal. Permanently attach flagangle and jamb brackets to door jamb and fully tighten all track bolts and whiz nuts.

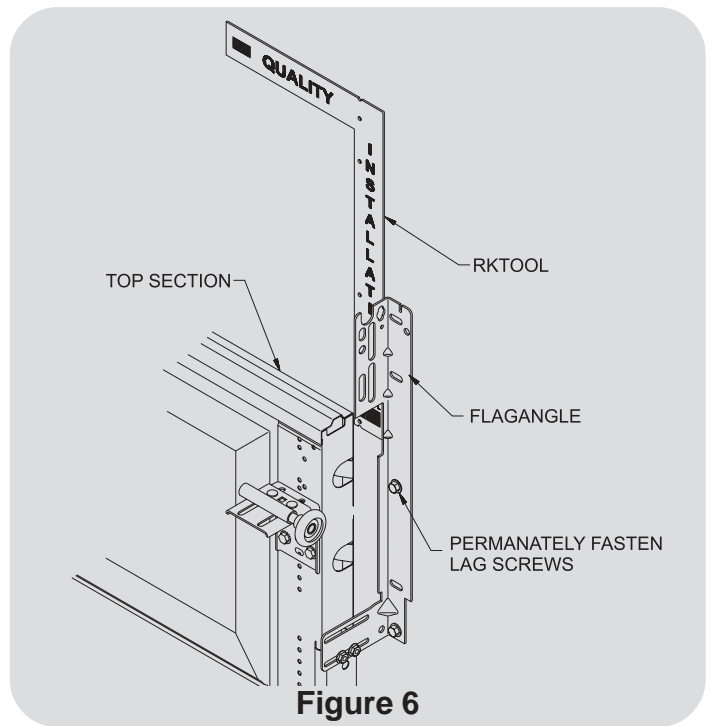

**Figure 6**

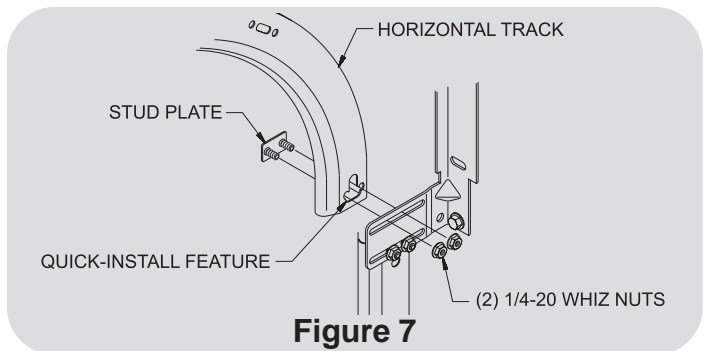

**Figure 7**

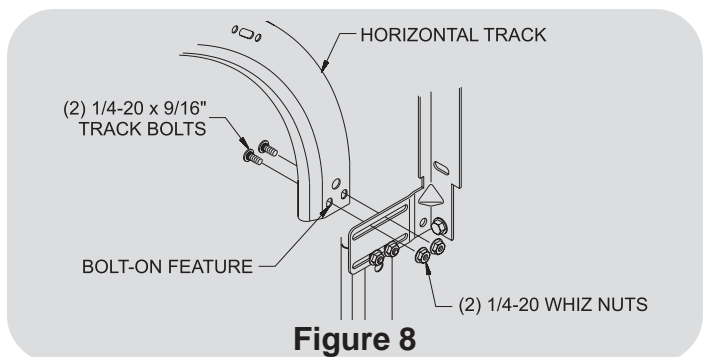

**Figure 8**

## INSTALLING THE HORIZONTAL TRACK

**Quick-Install Track System** - Attach the horizontal track at the quick-install feature using a stud plate and (2) 1/4-20 whiz nuts (See **Figure 7**).

**Bolt-On Track System** - Attach the horizontal track at the bolt-on feature using (2) 1/4-20 x 9/16" track bolts and whiz nuts (See **Figure 8**).

Continue the door installation per the main installation manual provided with the door.