

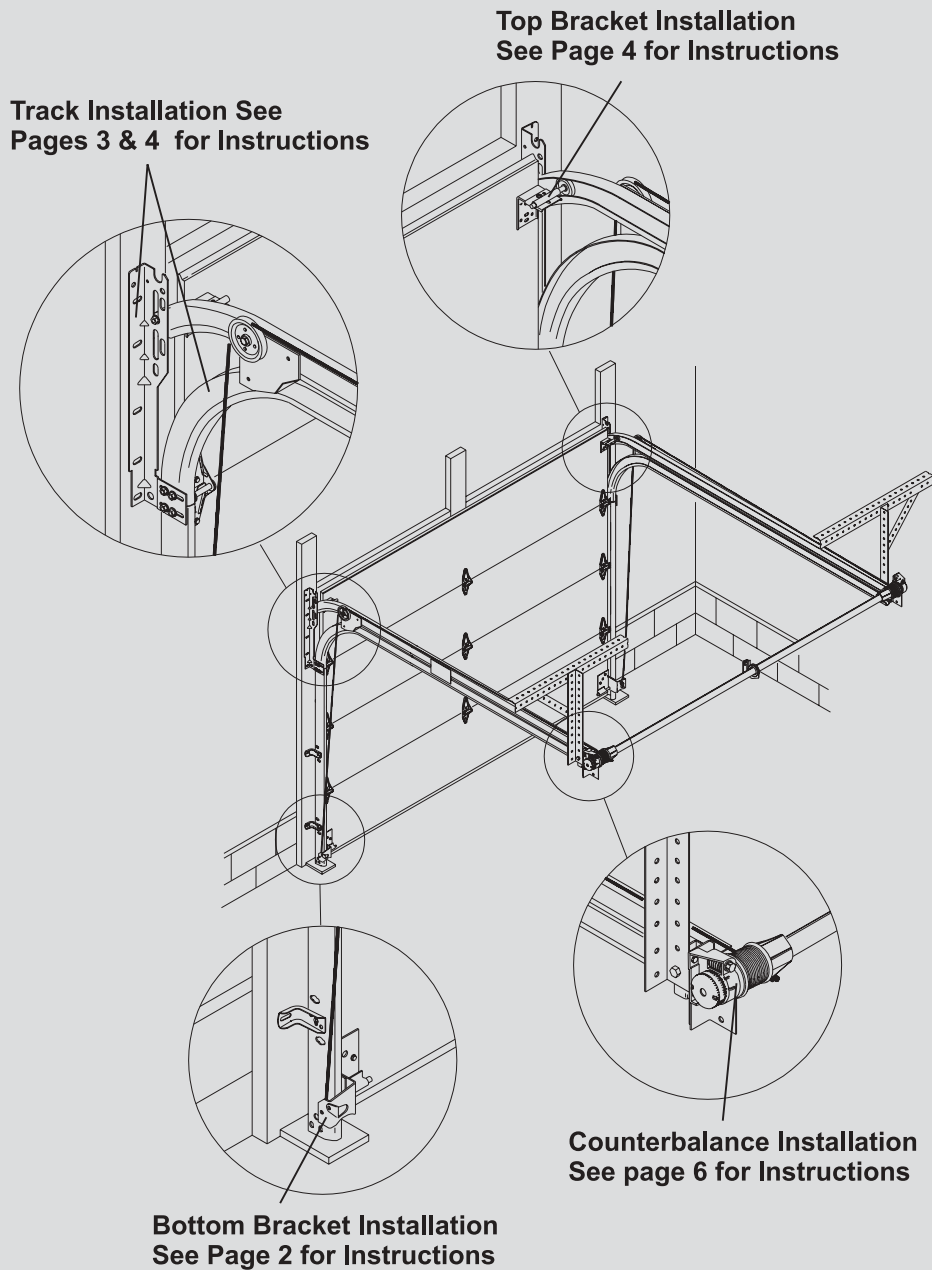

www.wayne-dalton.com

# Rear Mount TorqueMaster™ Low-Headroom Installation Instructions

## Double Track - Outside Hook-up



### IMPORTANT !

THIS INSTALLATION INSTRUCTION IS TO BE USED AS A SUPPLEMENT TO THE MANUAL PROVIDED WITH THE DOOR. THE FIGURES AND INSTRUCTIONS INCLUDED IN THIS DOCUMENT ARE **ONLY** THOSE WHICH DEVIATE FROM THE STANDARD INSTALLATION. **ALL** WARNINGS AND CAUTIONS LISTED IN MANUAL ARE APPLICABLE TO THIS LOW-HEADROOM INSTRUCTION AS WELL.

## Bottom Bracket Installation

Place the bottom section face down over a minimum of (2) padded sawhorses. Locate the low-headroom bottom brackets provided for your door (shown in **Fig. 1**) and place them, left and right over the bottom corners of the section. Seat the brackets against the edge of the section. Secure the bottom brackets to the section using (5) 1/4-20 x 5/8" self drilling / self tapping screws each for all steel doors except WayneGard™ Series where (6) are required. Wood doors require (5) 1/4-20 x 1-7/8" carriage bolts and hex nuts in each bottom bracket. Using the bracket as a template, mark

the location of the bolts. Drill a 9/32" dia (7mm) hole through the section at each bolt location, and secure the brackets to the section with the carriage bolts. Identify the cable type. Secure the looped counterbalance cables by hooking them over the milford pins on the bracket. Attach the spooled cables by placing the spool in line with the holes in the bracket, sliding the clevis pin through the holes and cable spool. Secure the pins using a 3/8" flat washer and cotter pin each. Place a roller through the holes or rolled tube in each bottom bracket.

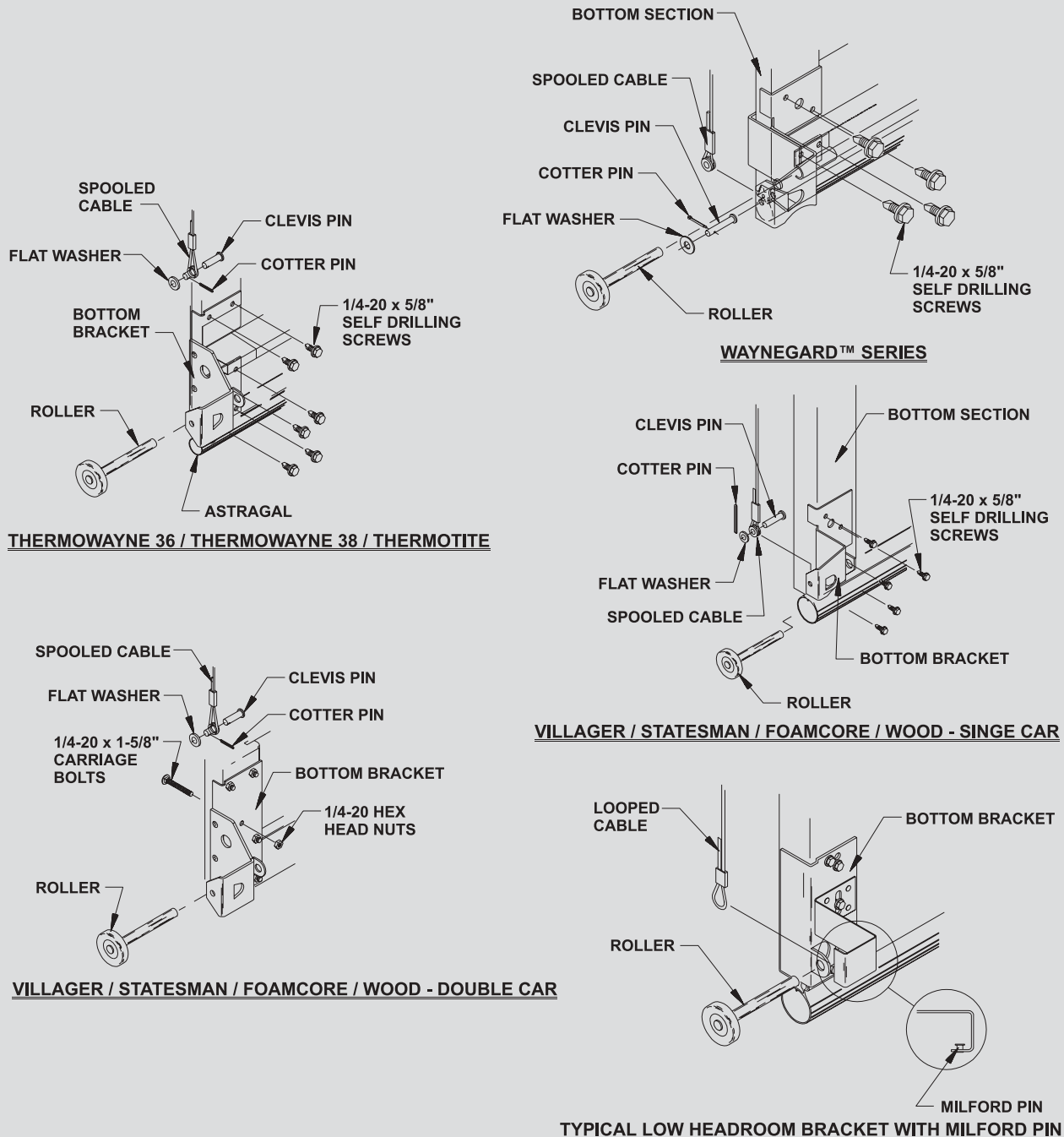

Fig. 1  
2

## Bracket Mount Vertical Track Installation

Place the lower slots of the flagangles over the ends of the vertical tracks with the 9/32" dia. (7mm) holes. See **Fig. 2**. (**Do not connect to slotted ends**) Attach the flagangles using (2) 1/4-20 x 9/16" track bolts and flanged hex nuts each.

**NOTE:** The spacing from the end of the flagangle to the track will vary with the width of the door. The spacing must be door width plus 5/8" (16mm).

Locate the jamb brackets shown in **Fig. 2**. Place (1) jamb bracket over each of the lower holes in the track. Space the edge of the brackets the thickness of the door away from the back edge of the track. Secure the brackets to the track using (1) 1/4-20 x 9/16" track bolt and nut. After the track is installed, secure the center jamb brackets to the track near the top of the second section.

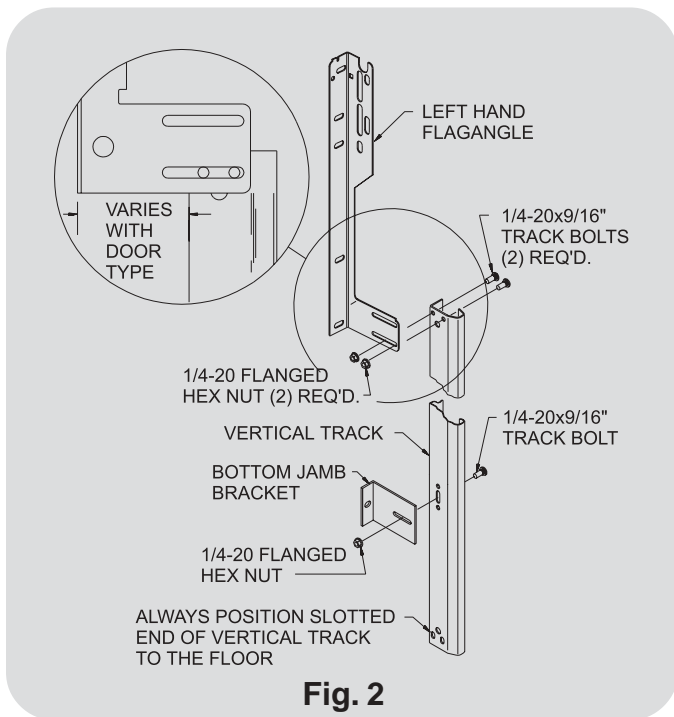

## Bracket Mount Horizontal Track Installation

Place the horizontal tracks over the top of the previously installed vertical tracks as shown in **Fig. 3**. Attach the bottom of the lower curve to the flagangle using (2) 1/4-20 x 9/16" track bolts and nuts. Secure the upper curve to the flagangle using (1) 1/4-20 x 9/16" track bolt, 3/8" flat washer and flanged hex nut as illustrated.

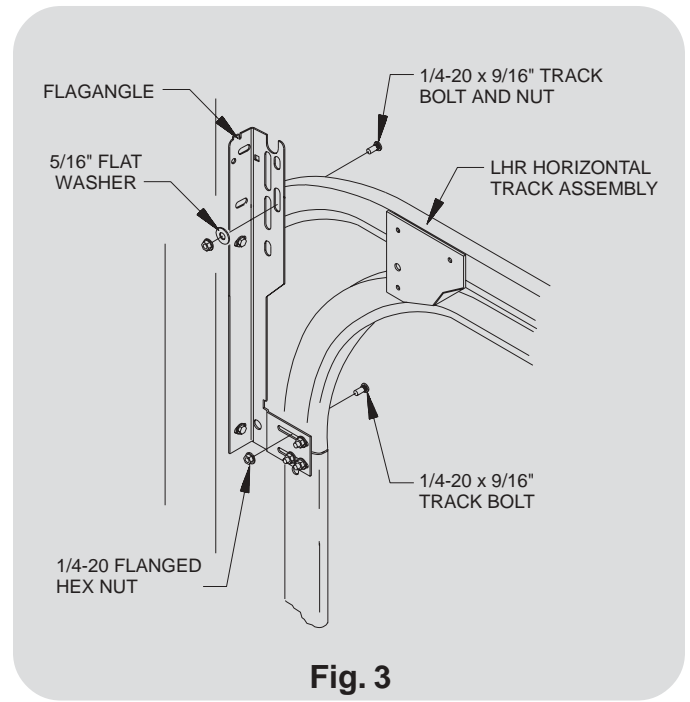

## Clip Mount - Optional Jamb Bracket Installation

Secure the center and lower jamb brackets to the wall angle through the hole below the track clip as shown in **Fig. 4**. Secure the top jamb bracket through the hole above the splice plate.

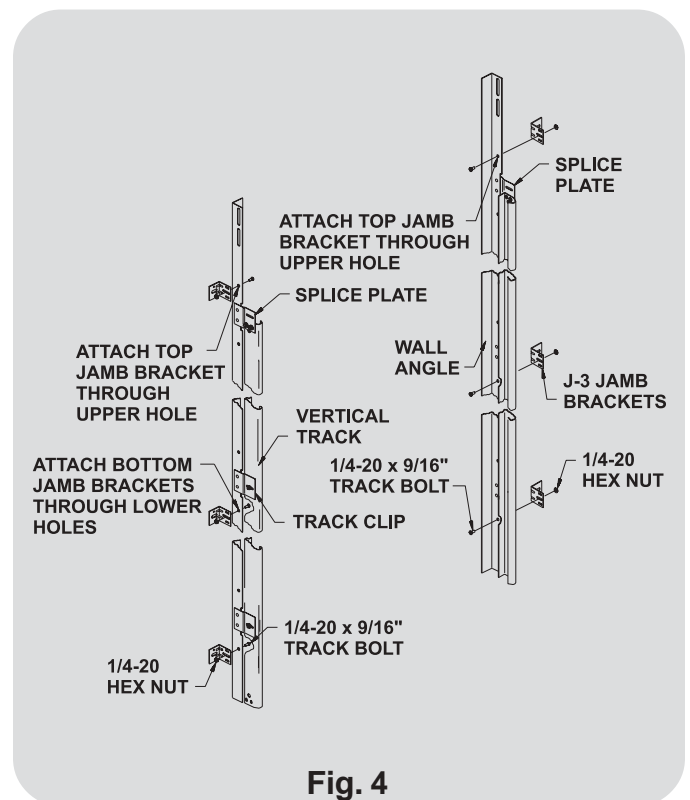

## Clip Mount Horizontal Track Installation

Place the horizontal tracks over the top of the previously installed vertical tracks as shown in **Fig. 5**. Attach the bottom of the lower curve to the splice plate using (2) 1/4-20 x 9/16" track bolts and nuts. Secure the upper curve to the wall angle as well using (1) 1/4-20 x 9/16" track bolt, 3/8" flat washer and flanged hex nut as illustrated.

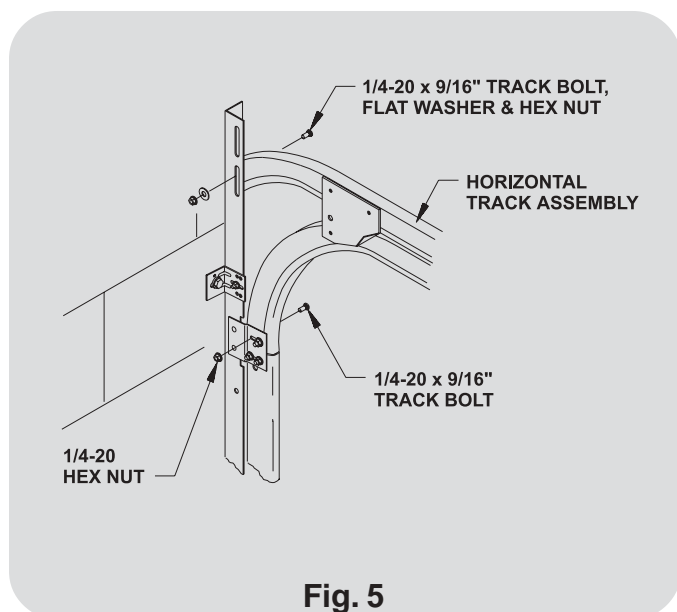

**Fig. 5**

## Top Bracket Installation

Identify the top bracket supplied with your door. Place a roller into the top bracket as shown in **Fig. 6**. Push the top section of the door out against the jamb until the section is parallel with the other sections of the door. Twist the roller into the upper track and locate the top brackets against the section. Align the edge of the top bracket with the edge of the section. Secure the top brackets to the section on all doors except WayneGard™ Series by placing (1) 1/4-20 x 5/8" self drilling / self tapping screw through the slot in each bracket. Adjust the brackets if necessary and place (2) more screws through the top holes as shown. For WayneGard™ Series doors repeat the above placing the notch in the top bracket over the intergal rib. Secure the brackets using (4) 1/4-20 x 5/8" self drilling / self tapping screws each.

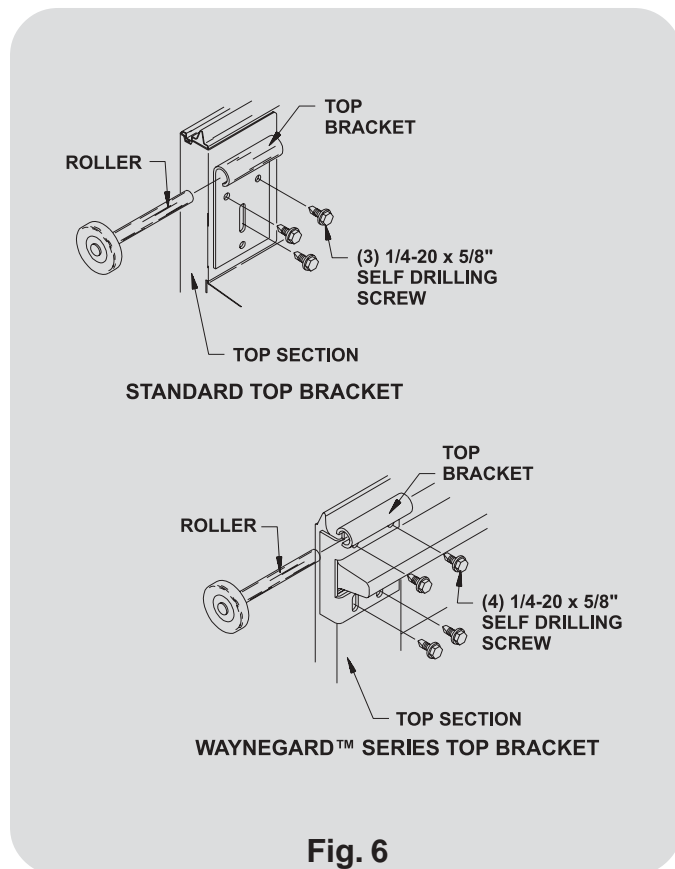

**Fig. 6**

## Mounting the Back Hanger Assembly

**(3) PIECE BACK HANGER SUPPLIED BY OTHERS** (NOTE: LATERAL BRACE MUST ALWAYS BE USED TO PREVENT SWAYING IN THE HORIZONTAL TRACK.)

**WARNING**  
THE BACK HANGER ANGLES MUST BE ATTACHED TO FRAMING MEMBERS IN THE CEILING ADEQUATE TO HOLD THE WEIGHT OF THE DOOR. OTHERWISE, THE DOOR COULD FALL WHEN RAISED INTO THE HORIZONTAL TRACKS, CAUSING INJURY OR PERMANENT DOOR DAMAGE.

From a 1-1/2" x 1-1/2" (38mm x 38mm) perforated angle (NOT PROVIDED) cut (2) 30" (762mm) pieces for horizontal angles, (2) 12" (305mm) pieces for bracing angles, and (2) pieces 6" (152mm) for drop angles.

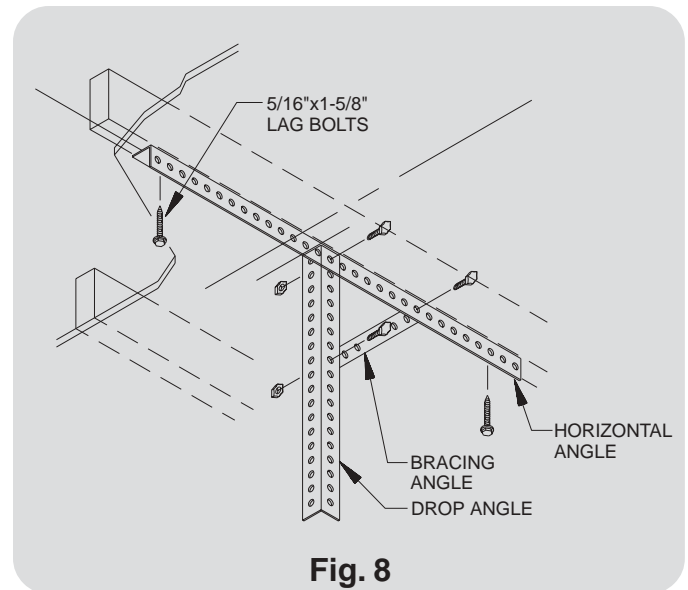
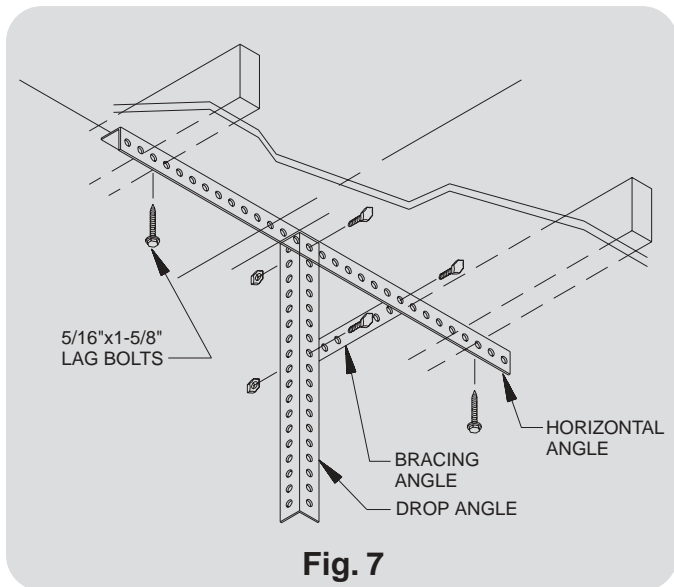

## TorqueMaster™ Mounting Plate Assembly

Determine the direction of the ceiling framing members (**Fig's. 7 & 8**). If the members run perpendicular to the door (**Fig. 7**), place the horizontal angles over (2) ceiling members in line with the ends of the horizontal track and fasten to ceiling using (2) 5/16" x 1-5/8" lag bolts. Place the drop angles vertically in line with the hole in the rear of the track and bolt to the horizontal angles. Place the bracing angle diagonally across the angles as illustrated and bolt together. If the ceiling members run parallel to the door, place the horizontal angles over the nearest member to the end of the track and secure to ceiling using (2) 5/16" x 1-5/8" lag bolts as illustrated in **Fig. 8**. Locate the drop angles vertically in line with the hole in the rear of the track and bolt to horizontal angles. Place the bracing angle diagonally across the angles as illustrated and bolt together.

### NOTE:

See instruction manual for details on how to locate the back hanger angles square with the door.

Bolt the TorqueMaster™ Adapter Brackets to the TorqueMaster™ Track Mounting Plates through the holes shown in **Fig. 9** with (2) 5/16" x 1" hex head bolts and nuts. Level and square the horizontal track (**spacing between the left hand and the right hand TorqueMaster™ Adapter Brackets must be door width plus 5-3/8" (136 mm) with a tolerance of plus 1/4" (6mm) and minus 0**). Lay a level on the horizontal portion of the track and raise the rear of the track to a level or slightly higher than level position, then place (2) 3/8-16 x 1-1/2" truss head bolts through the TorqueMaster™ track mounting plate (threads sticking out) and slide the drop angles over the bolts and secure with (2) 3/8" nuts each. (See **Fig. 9**)

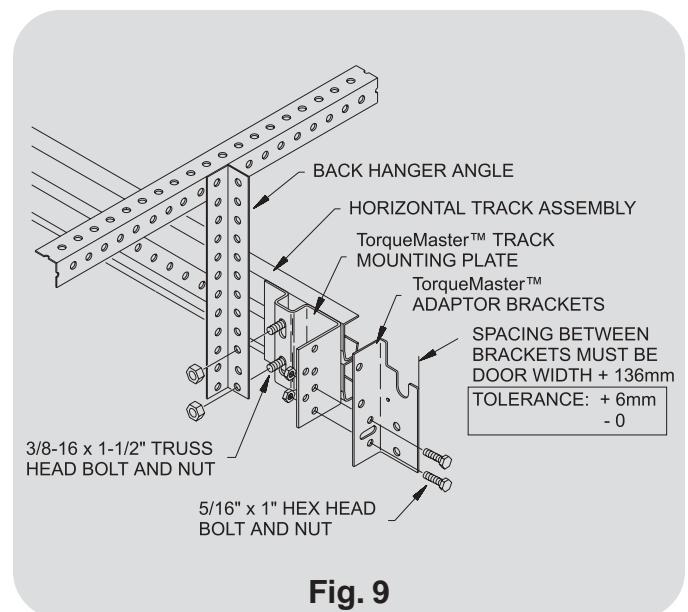

## TorqueMaster™ Tube Assembly

Place the TorqueMaster™ tube on the floor in front of the door, (inside looking out) with the red winding shaft on the left side. Align the cam of the center bushing with the torque tube and slide the bushing to the center of the tube. Place the right and left hand cable drums over the ends of the tube as illustrated in **Fig. 10**. Pull on the winding shafts to make sure they are fully extended through the cable drums.

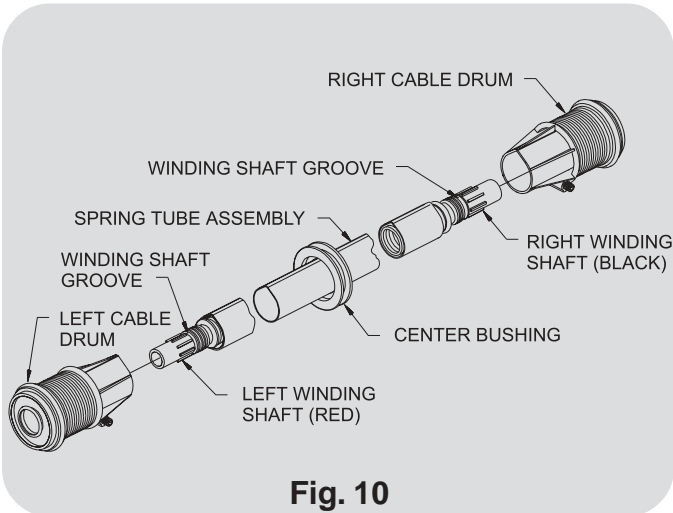

**Fig. 10**

## TorqueMaster™ Tube Installation

Lift the TorqueMaster™ tube assembly up. Align the winding shaft grooves with the notches in the TorqueMaster™ Adaptor Brackets as shown in **Fig. 11**. Slide the tube assembly into the notches. Place a drive gear over the winding shaft. Once the gear is seated, apply oil to the teeth of the drive gear using the provided oil packet. Slide the correct end bracket (right or left) over the drive gear. Place (1) 5/16-18 x 1" hex head bolt through the top hole of the bracket and loosely secure with (1) 5/16" nut. Slide the TorqueMaster™ shim behind the bracket, and secure with a second 5/16" bolt and nut. Thread the #10-24 x 1/2" self tapping screw into the TorqueMaster™ adaptor bracket, then tighten both of the 5/16" bolts. Repeat for the opposite end.

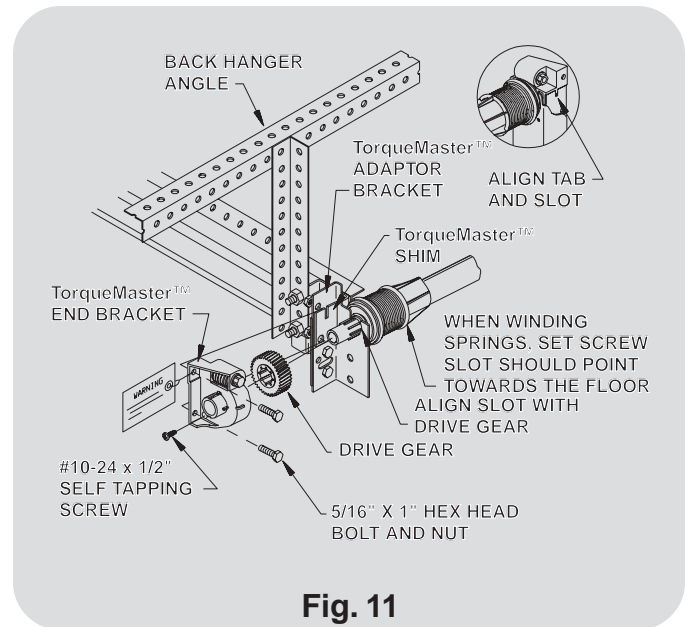

**Fig. 11**

## Center Bracket Installation

Single car doors - Locate the center of the TorqueMaster™ tube. Double car doors - (2 brackets required) divide tube length equally into three parts. Secure a perforated angle set to the ceiling, similar to the rear hanger as near to this (these) location(s) as possible. Place the center support bracket in line with the perforated angle as shown in **Fig. 12**. Secure the support bracket(s) using (2) 5/16" X 1" bolt and nut. (supplied by others.) Once the bracket(s) are installed, bend the tab(s) on the bracket(s) out to lock the center bushing into place.

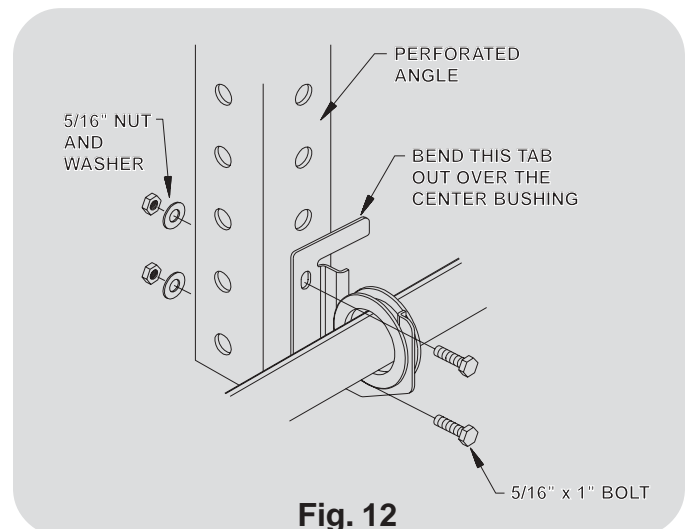

**Fig. 12**

## Cable Sheave Installation

Using the hole in the upper corner of the sheave plate closest to the door opening as a guide, drill a 10 mm dia. hole through the sheave plate and track (see **Fig. 13**). Place a 3/8-16 x 1-1/2" truss head bolt through the track and sheave plate. Slide a 4" steel sheave over the end of each bolt as shown. Secure the sheaves using (1) 3/8" hex nut over each bolt. Loop the counterbalance cables over each sheave.

### NOTE:

SEE PROVIDED INSTALLATION MANUAL FOR INSTRUCTIONS ON HOW TO WIND THE SPRINGS OF THE TorqueMaster™ COUNTERBALANCE SYSTEM.

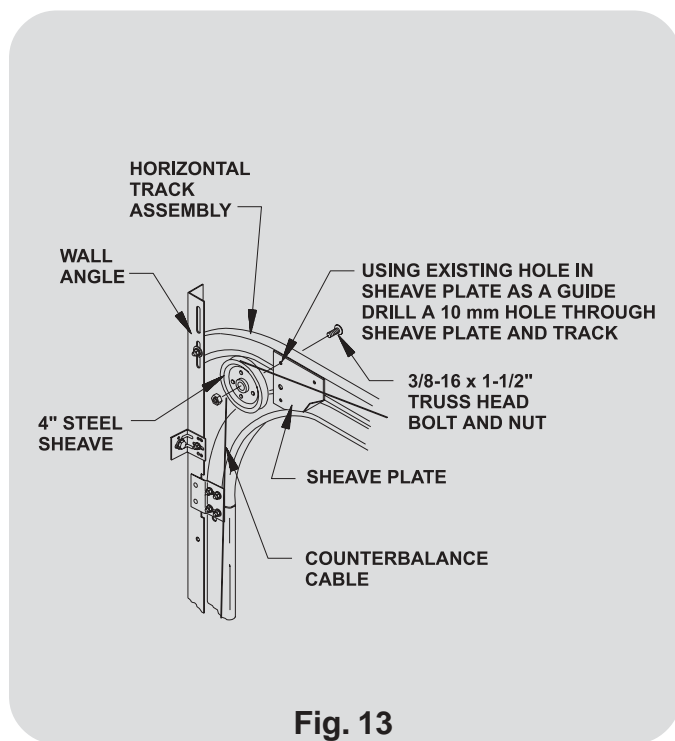

**Fig. 13**