



www.wayne-dalton.com

Front Mount TorqueMaster™ Low-Headroom Installation Instruction Supplement

This installation instruction is to be used as a supplement to the manual provided with the door. The figures and instructions included in this document are **ONLY** those which deviate from the standard installation. All **WARNINGS** and **CAUTIONS** listed in the manual are applicable to this low-headroom instruction as well.

Quick Install Jamb Brackets

Measure the length of the vertical tracks. Using the illustrations in **Fig. 1**, determine the placement of the jamb brackets for your door. Locate the proper jamb brackets by the corresponding holes in the vertical track.

NOTE: Jamb brackets are stamped for identification.

Quick Install Horizontal Track Installation

Place the horizontal tracks over the top of the previously installed vertical tracks as shown in **Fig. 2**. Locate the keyslot in the track over the Twistlock™ tabs on the flagangles. Hold the parts together and tap down on the track to lock into place. Place (1) 1/4-20 x 9/16" track bolt through the slot in the end of the top curve and the appropriate slot in the flagangle, then secure with a 3/8" flat washer and flanged hex nut (do not fully tighten). Level the horizontal track, then tighten the bolt in the top curve.

NOTE: Check the clearance between the upper curve and the jamb. The clearance must be a minimum of 5/8". If it is less than 5/8" trim the top curve with a hacksaw.

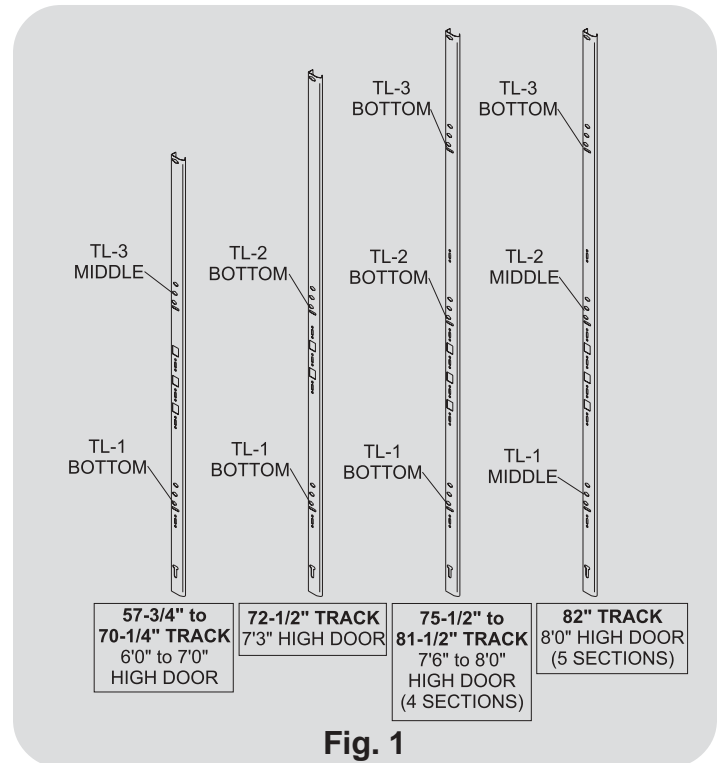

Fig. 1

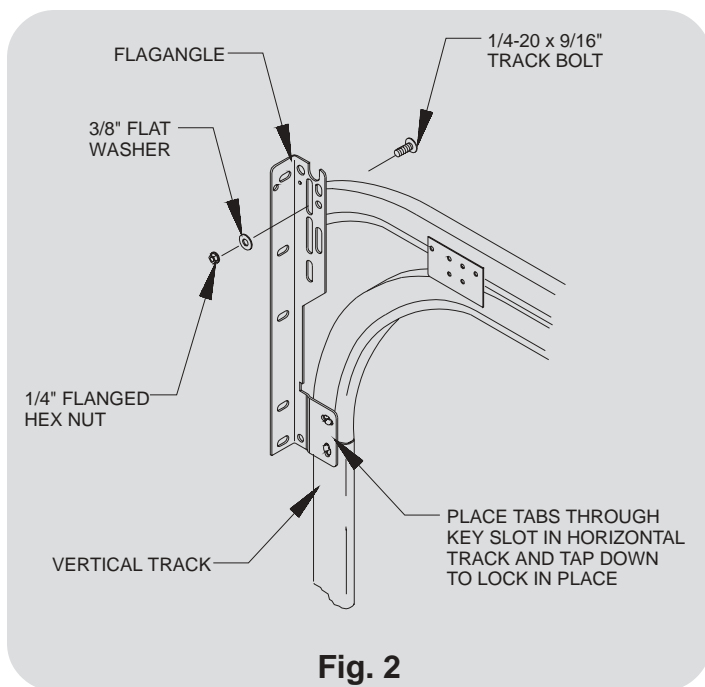

Fig. 2

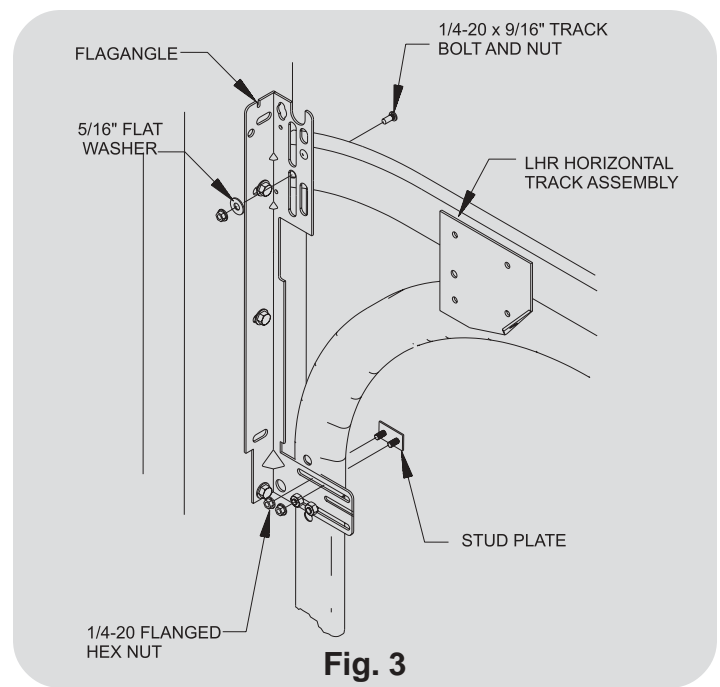

Fig. 3

300833

Universal Horizontal Track Installation

Place the horizontal tracks over the top of the previously installed vertical tracks as shown in **Fig. 3**. Attach the bottom of the lower curve to the flagangle using (1) stud plate and nuts. Secure the upper curve to the flagangle using (1) 1/4-20 x 9/16" track bolt, 3/8" flat washer and flanged hex nut as illustrated.

Top Bracket Installation

Identify the top bracket supplied with your door. Place a roller into the top bracket as shown in **Fig. 4**. Push the top section of the door out against the jamb until the section is parallel with the other sections of the door. Twist the roller into the upper track and locate the top brackets against the section. Align the edge of the top bracket with the edge of the section.

For 8000/8100/8200 door models, secure the top brackets to the section by placing (1) 1/4-20 x 5/8" self drilling screw through the lower slot in each bracket. Adjust the brackets if necessary and place (2) more screws through the top holes as shown.

For 9200/9600/9900 door models, secure the brackets using (4) 1/4-20 x 5/8" self-tapping screws each.

The space between the inside edge of the track and the section should be between 1/2" to 5/8", so that the roller stud head does not rub against the track as shown in **Fig. 4**.

NOTE: SEE THE PROVIDED INSTALLATION MANUAL FOR TORQUEMASTER™ INSTALLATION STEPS AND SPRING WINDING INFORMATION BEFORE INSTALLING THE REAR SUPPORTS.

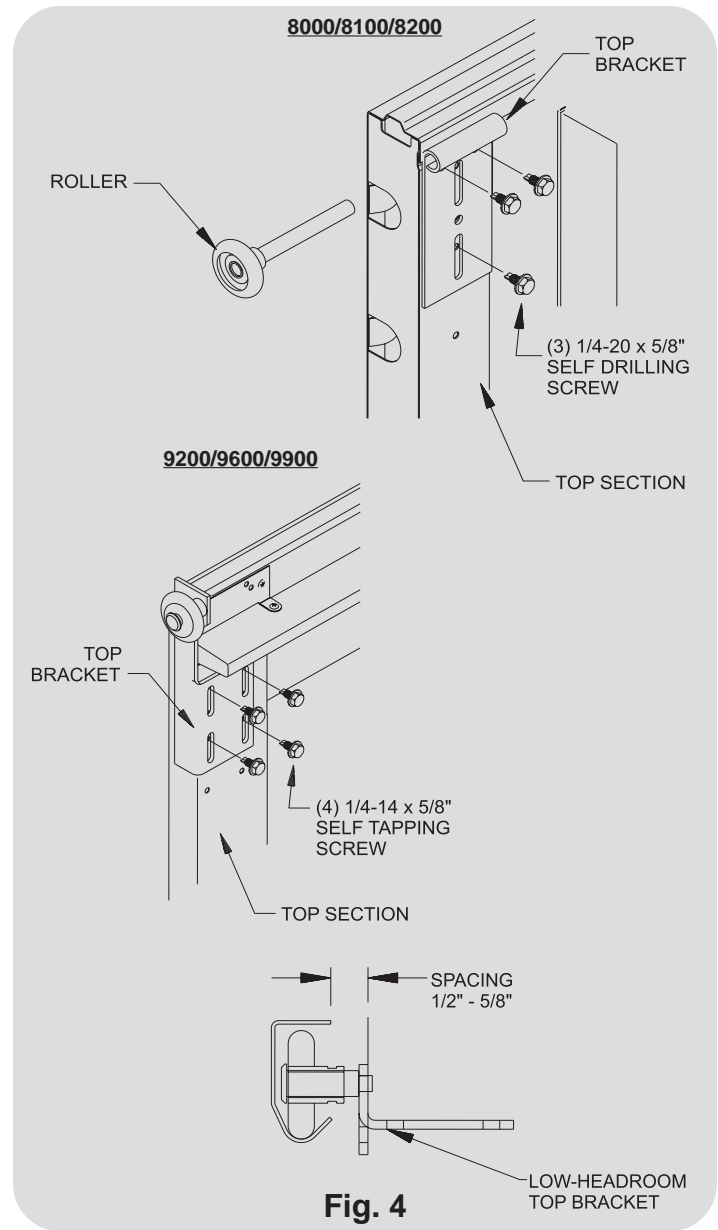

Fig. 4

Rear Support Installation

Clamp a pair of locking pliers onto the straight leg of each horizontal track 30-35" from the jamb to limit the travel of the door. Raise the door until the top roller hits the locking pliers previously installed and clamp a pair of locking pliers (below the bottom rollers) onto the straight leg of both vertical tracks to prevent the door from falling. Move the horizontal track until it is parallel with the edge of the door and level, then secure the rear support drop angle to the lower horizontal track using a 5/16-18 x 1-1/4" bolt and nut each as shown in **Fig. 5**. Attach a 1/4-20 x 1-1/4" bolt and nut each to the upper horizontal track to be used as a roller stop. Lower the door into the opening to finish the installation.

REAR SUPPORT MATERIAL SUPPLIED BY OTHERS (NOTE: LATERAL BRACE MUST ALWAYS BE USED TO PREVENT SWAYING OF HORIZONTAL TRACK.)

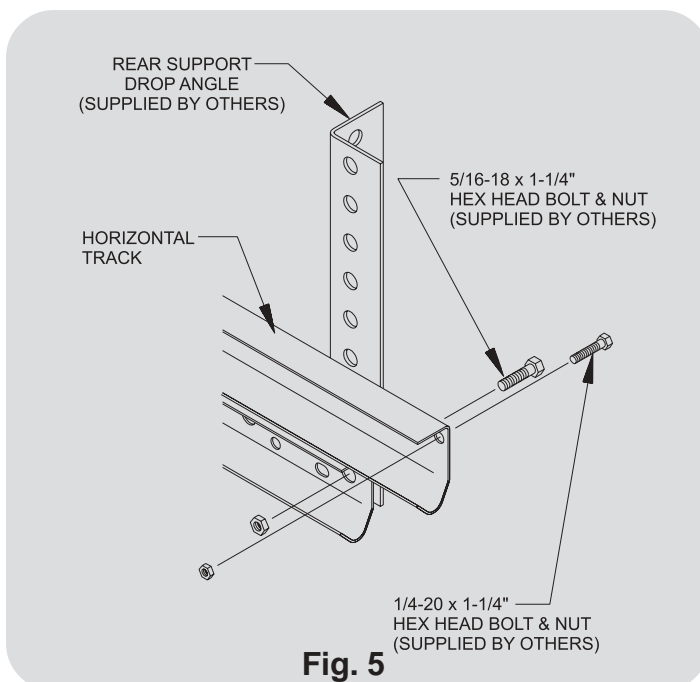

Fig. 5

Rear Mount TorqueMaster™

Low-Headroom Installation Instruction Supplement

Bottom Bracket Installation

Locate the low-headroom bottom brackets provided for your door (shown in **Fig. 1**) and place them, left and right over the bottom corners of the section. Seat the brackets against the edge of the section. Secure the bottom brackets to the section using (4) 1/4-20 x 5/8" self drilling screws and (1) tamper-proof screw. Attach the counter balance cable to the low-headroom bottom brackets using clevis pins. Secure the clevis pins using a 3/8" flat washer and cotter pin each. Place roller through holes or rolled tube in each bottom bracket.

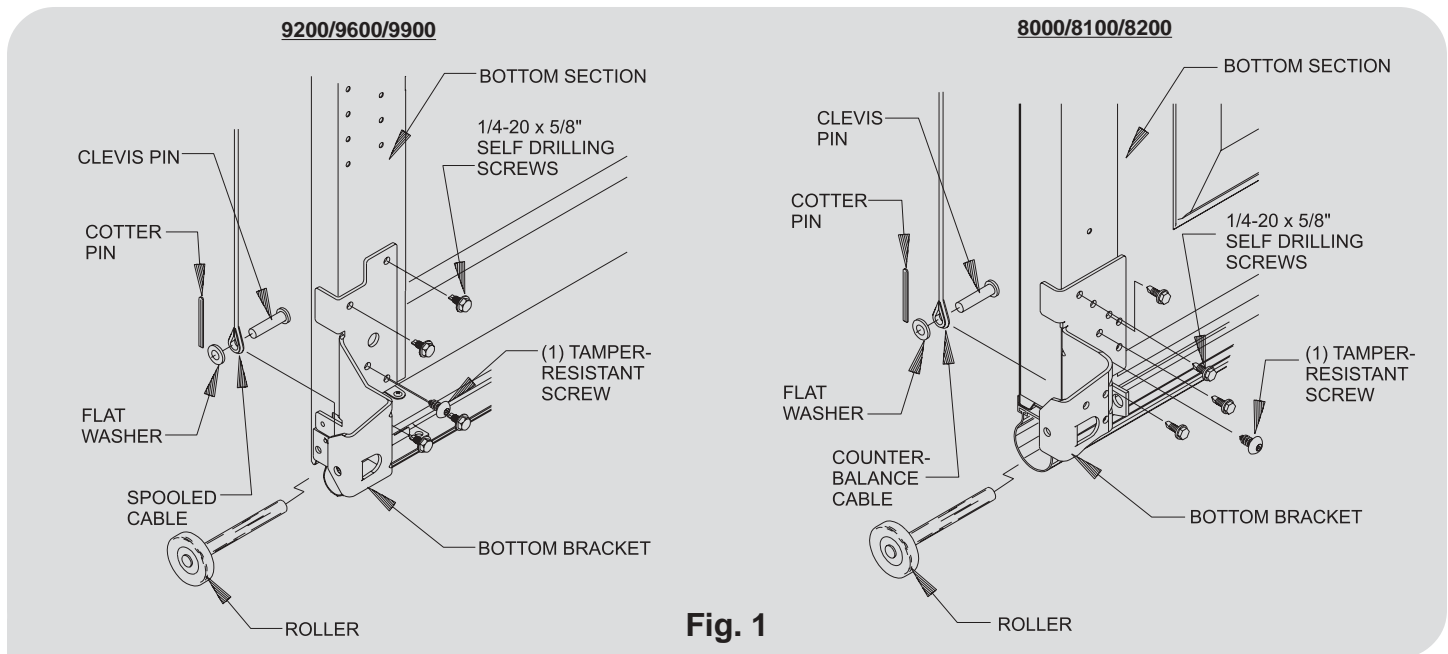
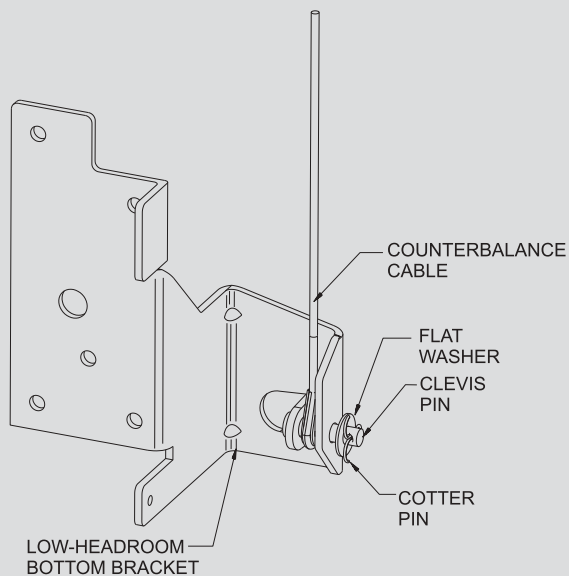

Fig. 1

COUNTERBALANCE CABLE INSTALLATION



Jamb Bracket Installation

See Quick Install Jamb Brackets in the Front Mount TorqueMaster™ section of this insert, or for Fully Adjustable Track see main manual.

Horizontal Track Installation

For 9200/9600/9900 door models, see Quick Install Horizontal Track Installation; for 8000/8100/8200 door models, see Universal Horizontal Track Installation in the Front Mount TorqueMaster™ section of this insert.

Top Bracket Installation

See Top Bracket Installation in the Front Mount TorqueMaster™ section of this insert.

Rear Support Installation

Level and square the horizontal track (spacing between the left hand and the right hand TorqueMaster™ Adapter Brackets must be door width plus 5-3/8" (136 mm) with a tolerance of plus 1/4" (6mm) and minus 0). Lay a level on the horizontal portion of the track and move the rear of the track to a level position, then place (2) 3/8-16 x 1-1/2" truss head bolts through the TorqueMaster™ track mounting plate (threads sticking out) and slide the drop angles over the bolts and secure with (2) 3/8" nuts each. (See **Fig. 2**)

Center Bracket Installation

For single car doors, locate the center of the TorqueMaster™ tube. For double car doors, (2 brackets required) divide tube length equally into three parts. Secure a perforated angle set to the ceiling, similar to the rear support, as near to this (these) location(s) as possible. Place the center bracket/bushing assembly in line with the perforated angle as shown in **Fig. 5**. Secure the support bracket(s) using (2) 5/16" x 1" bolts, washers, and nuts to the perforated angle(s).

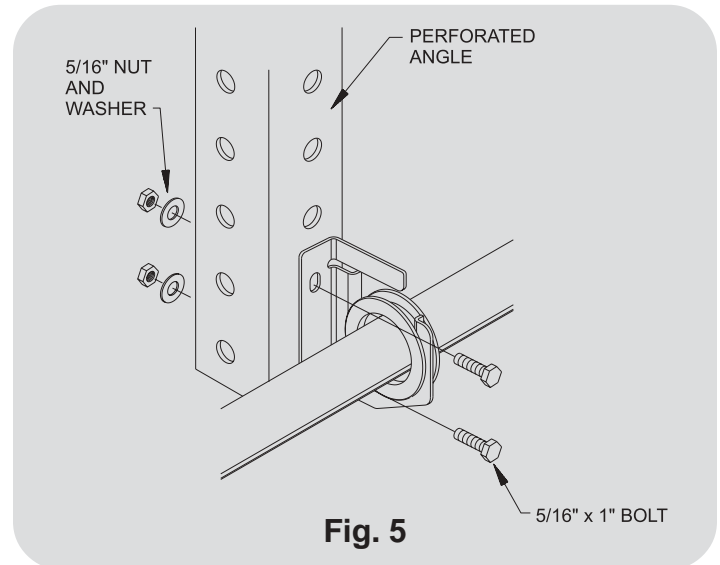

Fig. 5

Cable Sheave Installation

Using the appropriate hole in the sheave plate as a guide, drill a 13/32" dia. hole through the sheave plate and track (see **Fig. 6**). Place a 3/8-16 x 1-1/2" truss head bolt through the drilled hole and slide a steel sheave over the end of the bolt as shown. Secure the sheave using (1) 3/8" hex nut. Repeat for the other side, then loop the counterbalance cables over each sheave.

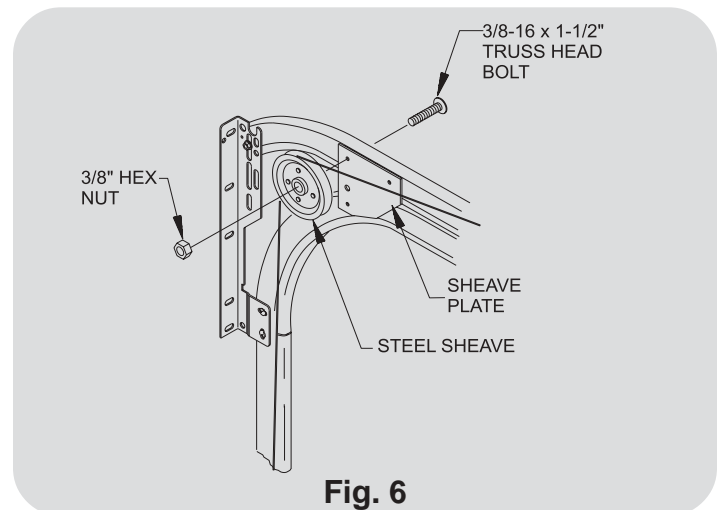

Fig. 6

NOTE: See provided installation manual for instructions on how to wind the springs of the TorqueMaster™ counterbalance system.

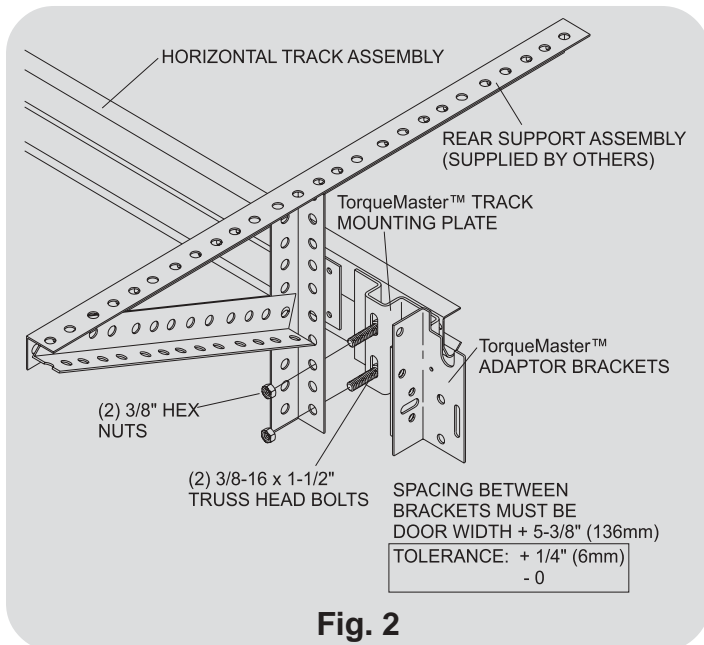

Fig. 2

TorqueMaster™ Tube Installation

Lift the TorqueMaster™ tube assembly up. Align the winding shaft grooves with the notches in the TorqueMaster™ Adaptor Brackets as shown in **Fig. 4**. Slide the tube assembly into the notches. Apply oil to the teeth of a drive gear using the provided oil packet and place the drive gear over the winding shaft. Slide the correct end bracket (right or left) over the drive gear. Place (1) 5/16-18 x 1" hex head bolt through the top hole of the bracket and loosely secure with (1) 5/16" nut. Slide the TorqueMaster™ shim behind the bracket, and secure with a second 5/16-18 x 1" bolt and nut. Thread the #10-24 x 1/2" self tapping screw into the TorqueMaster™ adaptor bracket, then tighten both of the 5/16" bolts. Repeat for the opposite end.

⚠ WARNING!
TORQUEMASTER TUBE IS NOT INTENDED TO SUPPORT WEIGHT. TO AVOID SERIOUS OR FATAL INJURY, DO NOT HANG OR SUPPORT ANY OBJECTS.

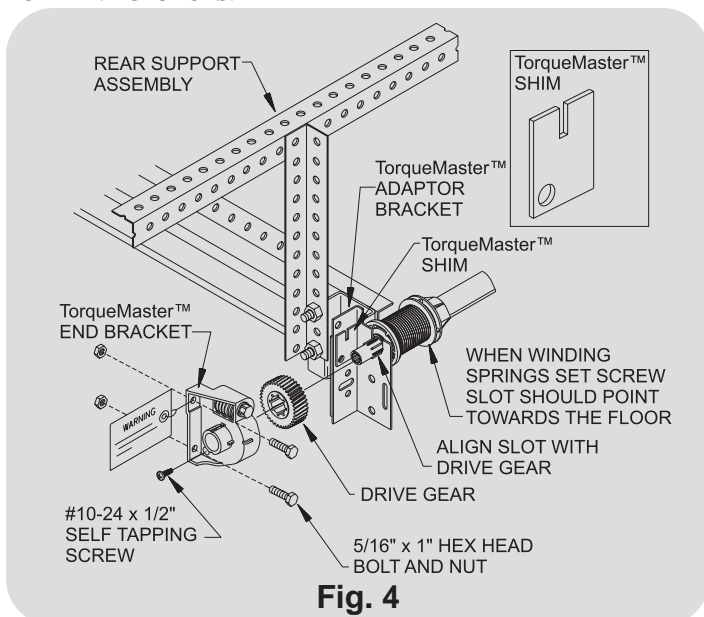

Fig. 4