



# START HERE

**IMPORTANT!** READ IMPORTANT SAFETY NOTICES AND REFER TO INSERT SHEET INSTRUCTIONS TITLED "REMOVING THE OLD DOOR/PREPARING THE OPENING". IF THE INSERT SHEET INSTRUCTIONS ARE NOT INCLUDED, CONTACT WAYNE-DALTON CORP. FOR A FREE COPY.

Begin the installation of the door by checking the opening. It must be the same size as the door. Vertical jambs must be plumb and the header level. Side clearance, from edge of door to wall, must be minimum of 3/16" (89mm) on each side for 2" track applications, and 4-1/2" (110mm) for 3" track applications. For proper opening preparation refer to the portion of the insert sheet instructions titled "Preparing the Opening". Check floor for level at opening. If floor is more than 1/4" out of level, the bottom section and/or floor will require modifications for proper door seal.

## WARNING!

REMOVAL OF AN EXISTING DOOR CAN BE DANGEROUS. FOLLOW INSERT SHEET INSTRUCTIONS CAREFULLY, OTHERWISE SERIOUS INJURY OR DEATH COULD RESULT. Finish painting must be completed before installation. Finishing instructions are attached to the back of the door and are included in this instruction manual.

All struts and door hardware must be applied as described in this instruction manual.

All 1/4 x 1" lag screws applied to the door, must be pilot drilled with 1/8" drill bit. All 5/16 x 1-5/8" or 2" lag screws applied to the jambs, must be pilot drilled with 3/16" drill bit.

Failure to comply with the Warnings & Instructions in this manual, renders the warranty null & void.

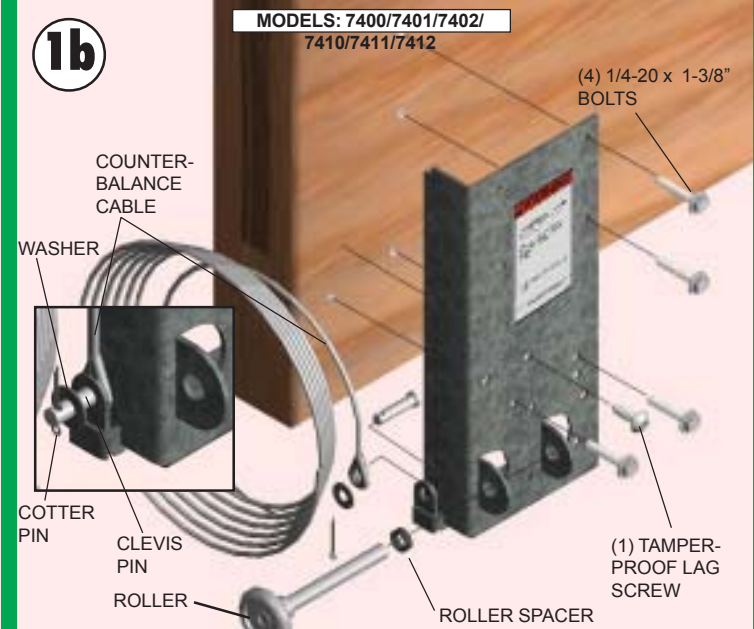
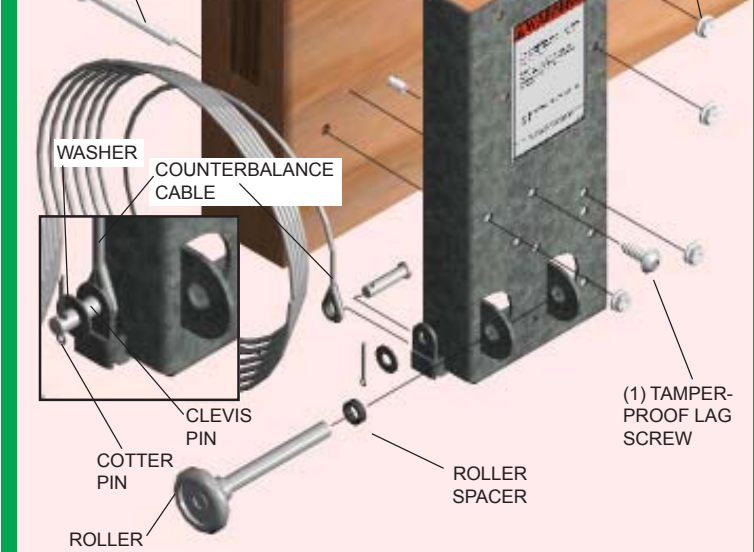

First, secure the counterbalance cable to the bottom bracket with the cotter pin, washer and clevis pin.

For models: 7420/7421 secure each bottom bracket with (4) carriage bolts and (1) tamper resistant lag screw (see 1a).

Models: 7400/7401/7402/7410/7411/7412 secure each bottom bracket with (4) 1-3/8" bolts into the factory installed prong nuts (see 1b). All end hardware will have factory installed prong nuts for models 7400/7401/7402/7410/7411/7412.

**NOTE:** Some doors may have pre-installed carriage bolts instead of prong nuts. Secure the brackets with hex head nuts.

**NOTE:** Only doors provided to professional installers, who have required tools will be supplied with a tamper-resistant fastener.

**IMPORTANT!** Right and left hand is always determined from inside the building looking out.

Attach astragal to bottom edge of section with 3/4" roofing nails (see 1c).

Models: 7400/7401/7402/7410/7411/7412 less than or equal to 7'3" high and models: 7420/7421 with 2" track applications receive #2 and #4 end hinges. 3" track applications get #4 and #6 end hinges.

Models: 7400/7401/7402/7410/7411/7412 between 7'4" and 8'6" high and Heritage doors will receive #1, #2, and #3 end hinges for 2" track applications and #3, #4, and #5 end hinges for 3" track applications.

Position the appropriate end hinges on the bottom section.

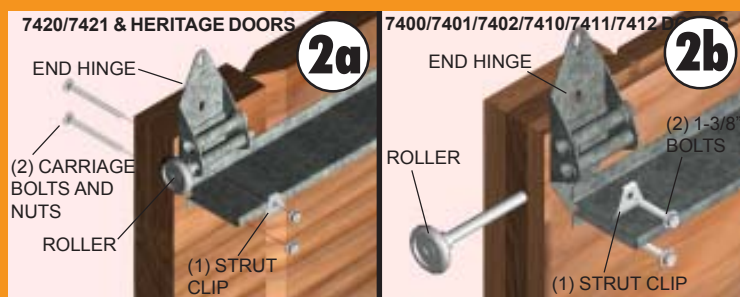

Lay one of the long struts over the end hinges. Identify your strut as 2" or 3" and secure to the hinges as shown in 2c or 2d. See **Schedule B: Strut and Hinge Placement** on the inside cover page to determine the placement of struts.

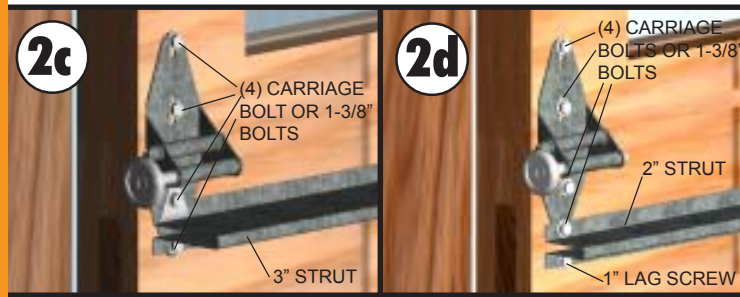

For 7400/7401/7402/7410/7411/7412 and Heritage doors place center hinges under strut where section is pilot drilled. Using the center hinge as a drill template, drill a 3/16" hole in the bottom strut leg at each hinge location. Align the bottom hole in the lower hinge leaf with the strut hole and the pilot hole in the section and secure hinge and strut using a 1" lag screw.

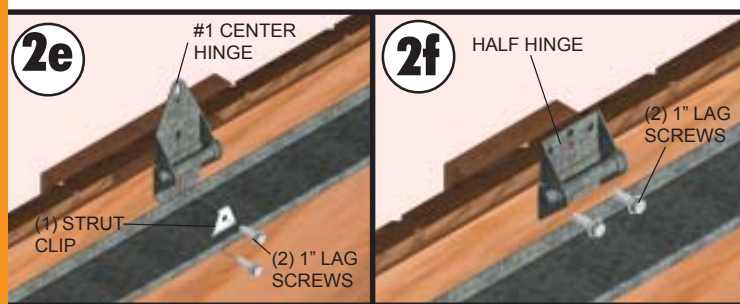

For Carriage Collection doors place center hinges under strut at every vertical stile. Using the center hinge as a template, drill a 3/16" hole in the bottom strut leg. Align the bottom hole in the lower hinge leaf with the strut hole, then pilot drill section and secure with 1" lag screws. Finish securing the center hinges and strut using a strut clip and 1" lag screw (see 2e).

For models 7400/7401/7402/7410/7411/7412, place half hinges equally spaced for a maximum of 30" apart from one another and from center hinges. Pilot drill and secure with 1" lag screws (see 2f). Install the short strut 3/4" up from the bottom edge of the bottom section using (2) 1" lag screws at each end and approximately 30" on centers. See **Schedule B: Strut and Hinge Placement** on the inside cover page.

**IMPORTANT!** When placing rollers into end hinges number 2 and higher, the roller goes into tube furthest away from section.

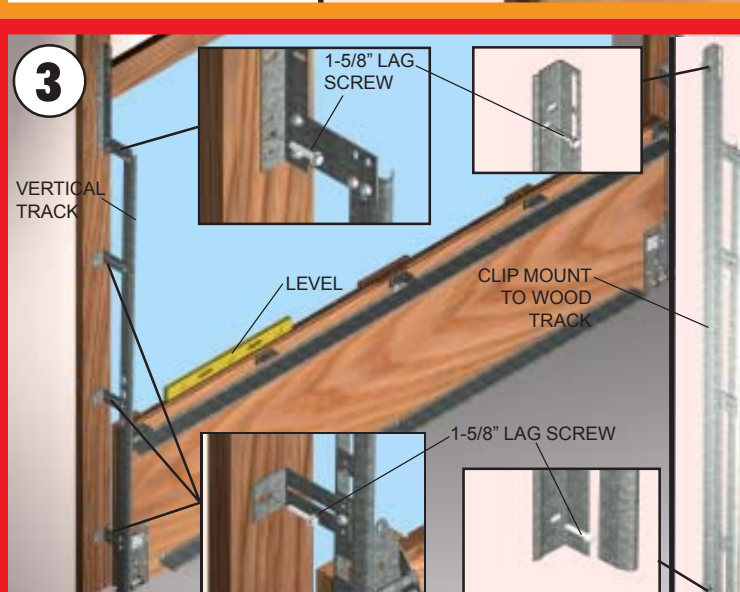
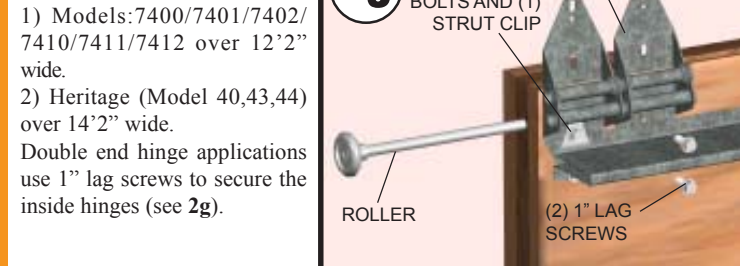

Before installing the bottom section, measure and cut perimeter seal (not included) for entire garage door opening. Perimeter seal must be installed prior to door installation. Attach the perimeter seal to the door jamb 1/8" to 1/4" past door jamb (see figure below). Temporarily nail the perimeter seal to the door jambs and header. This will help hold the bottom door section in place. Refer to the insert sheet on preparing the opening.

Now comes the single most important step in installing the Wayne-Dalton garage door system. Center the bottom section in the door opening. Level it using wooden shims under the bottom astragal as needed. Once the bottom section is level, all the other components will automatically align. Hold the section in the opening while attaching vertical tracks.

Position the vertical track over the rollers of the bottom section. Make sure the counterbalance cable is located between the rollers and the door jamb. Loosely fasten bottom jamb bracket and flagangle with (1) 1-5/8" lag screw each or (2) 1-5/8" lag screws for Clip Mount to Wood (CMW) track. Run the counterbalance cable up between vertical track and edge of door section. Hang the cable over the top of the flagangle. Repeat for other side.

**NOTE:** In the event that the bottom section was shimmed to level it, then the vertical track on that same side of the section must be raised the thickness of the shim(s). The tops of the vertical track must be level.

Install end hinges, center hinges, and struts prior to placing the door into the door opening. Position the appropriate end hinges on the upper corners of the second section. Place the long strut over end hinges and center hinge and secure the strut and hinges to the section (see Fig. 2a to 2g). Half hinges must align with the half hinges installed on the bottom section (see Fig. 2f). Make sure top leaf of all hinges on the bottom section are folded down. Insert rollers into the end

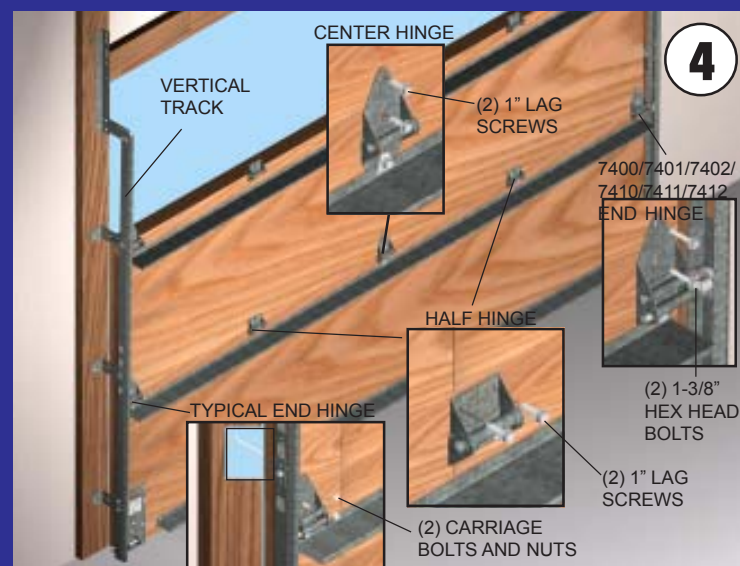

hinges of the second section. With assistance lift section and place rollers over the tops of the vertical tracks. Install by guiding rollers into the vertical track on both sides and gently lowering this section into the bottom section. Align the trim between the bottom and second section. (Models 7400/7401/7402/7410/7411/7412/7420/7421 with 3 sections require 2 struts on lock section. See **Schedule B: Strut and Hinge Placement** on the inside cover page before securing upper hinge leaves.) Flip up the hinge leaves on the bottom section and secure all center hinges (half and full height) and the second set of end hinges for double endstie applications with (2) 1" lag screws. End hinges are secured with carriage bolts and nuts or 1-3/8" bolts into pre-installed prong nuts for models: 7400/7401/7402/7410/7411/7412. Install other section(s), except top section, in same manner.

**NOTE:** Models 7400/7401/7402/7410/7411/7412 with 4 sections have (2) struts on the 3rd section. (**NOTE:** Follow the typical practice when installing struts to the lower edge of sections (over upper hinge leaves), but reverse the side at which the strut clip is used.) See **Schedule B: Strut and Hinge Placement**.

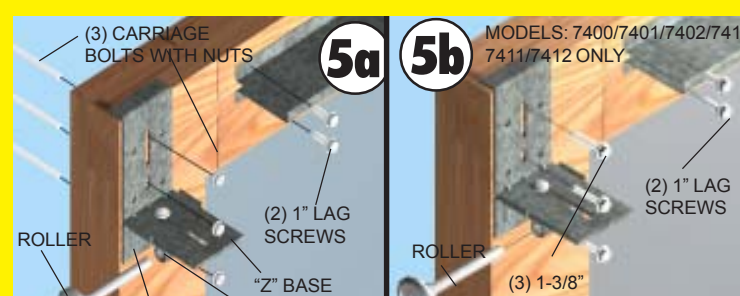

Top Brackets: The "Z" base and "L" bracket fit together as shown. The slide fits into the "L" bracket and is secured with a carriage bolt and nut. Secure top bracket to upper ends of the top section with (3) carriage bolts or 1-3/8" bolts for models 7400/7401/7402/7410/7411/7412.

For double top brackets, position the second bracket next to the first top bracket and secure with (3) 1" lag screws.

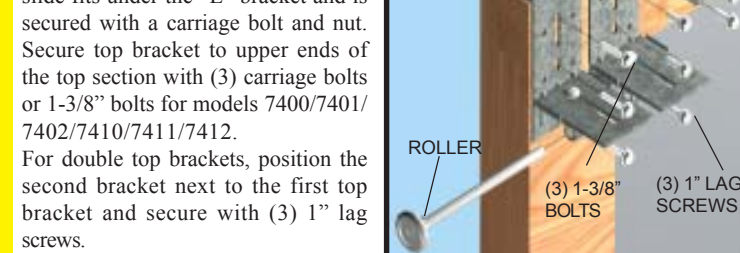

Center and position the short strut 3/4" below the top edge of the top section. Secure with (2) 1" lag screws at each end, and approximately every 30" on centers. Stack the top section in opening and drive a nail into the header and bend over section to keep top section in place.

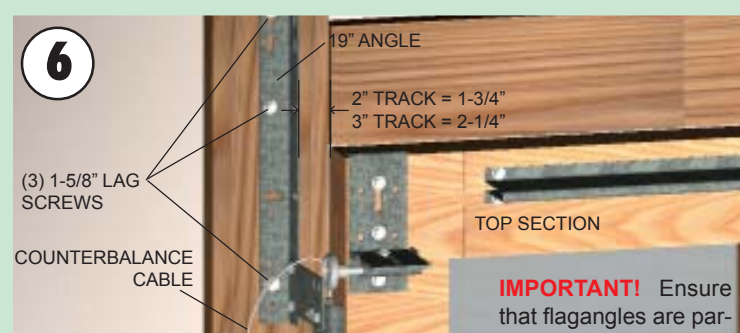

For 2" track, position flagangle/19" angle/Texas Wall Angle 1-11/16" (43mm) to 1-3/4" (44mm) from the edge of the door. For 3" track position 2-1/4" (57mm) from edge of the door. Tighten the first lag screw then secure flagangle to the jamb with 2 more 1-5/8" lag screws. Now complete the vertical track installation on both sides by tightening all the lag screws in the jamb brackets/Texas Wall Angle.

**IMPORTANT!** Vertical tracks must be secured so that the rollers are touching the deepest part of the curved side of the track.

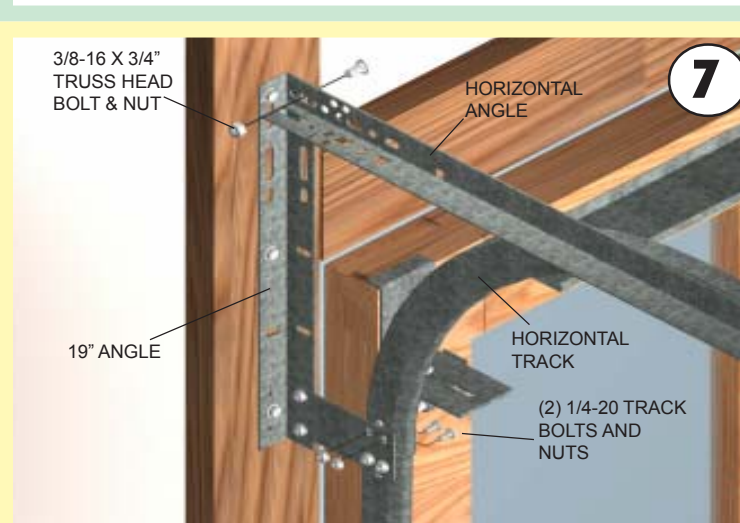

To install horizontal track, place the curved end over the top roller. Align the bottom of the horizontal track with the top of vertical track. Level the track and secure to the flagangle with (2) 1/4-20 track bolts and nuts. Bolt the reinforcing angle to the slot in the flagangle using (1) 3/8-16 x 3/4" truss head bolt and nut. Repeat for other side. With tracks installed you can adjust the top brackets. Remove the nail from above the top section and vertically align the top section with the lower sections. Once aligned, position top roller in adjustable slide against horizontal track to maintain position and tighten nut. Repeat for other side. Finally secure the hinges to the top section.

**IMPORTANT!** Failure to remove nail before attempting to raise door could cause permanent damage to top section.

**WARNING!** DO NOT ATTEMPT TO RAISE DOOR AT THIS POINT.

**IMPORTANT!** DOOR OPENING PREPARATION IS CRITICAL FOR PROPER DOOR INSTALLATION. REFER TO INSERT SHEET "PREPARING THE OPENING" BEFORE INSTALLING NEW DOOR.

**IMPORTANT!** REAR SUPPORT ASSEMBLIES MUST BE SECURELY ATTACHED TO CEILING FRAMING MEMBERS ADEQUATE TO HOLD THE WEIGHT OF THE DOOR.

**NOTE:** SINGLE WIDE DOOR SHOWN IN ILLUSTRATION.

**IMPORTANT!** JAMBS, HEADER AND SPRING PAD MUST BE SECURELY ATTACHED TO FRAMING MEMBERS. CHECK BEFORE INSTALLING NEW DOOR.

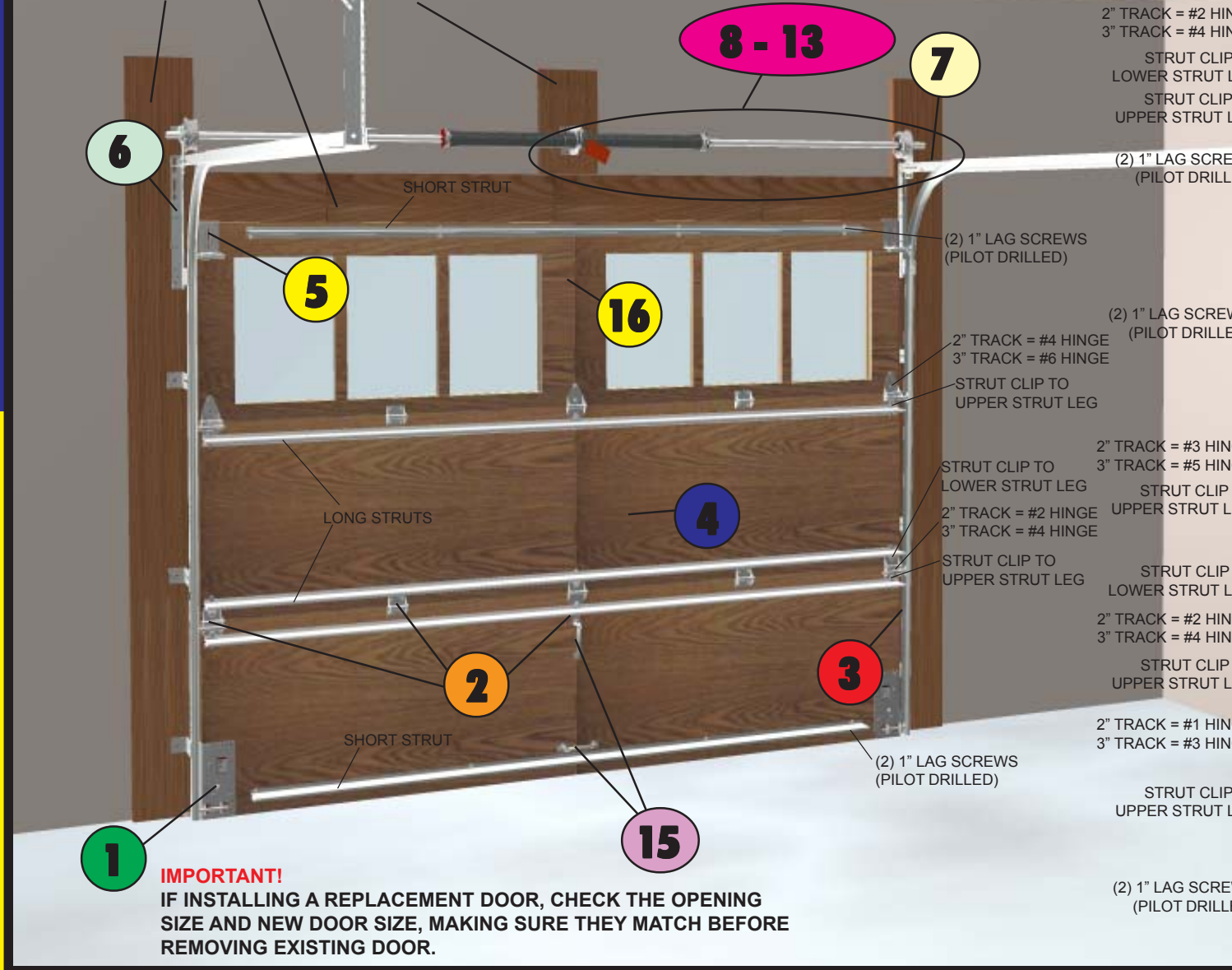

**IMPORTANT!** IF INSTALLING A REPLACEMENT DOOR, CHECK THE OPENING SIZE AND NEW DOOR SIZE, MAKING SURE THEY MATCH BEFORE REMOVING EXISTING DOOR.

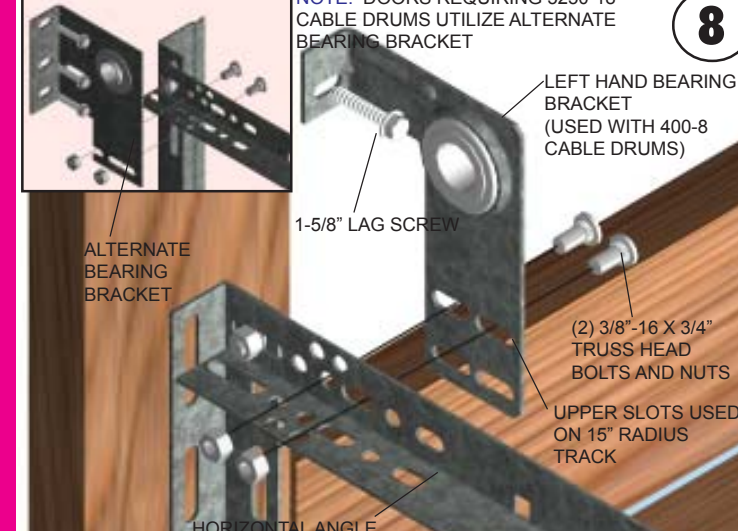

Locate the end bearing bracket above the flagangle and secure the bracket to the horizontal angle using (2) 3/8-16 x 3/4" truss head bolts and nuts. Once the bracket is secured to the reinforcing angle, secure the bracket to the jamb using (1) 5/16" x 1-5/8" lag screw.

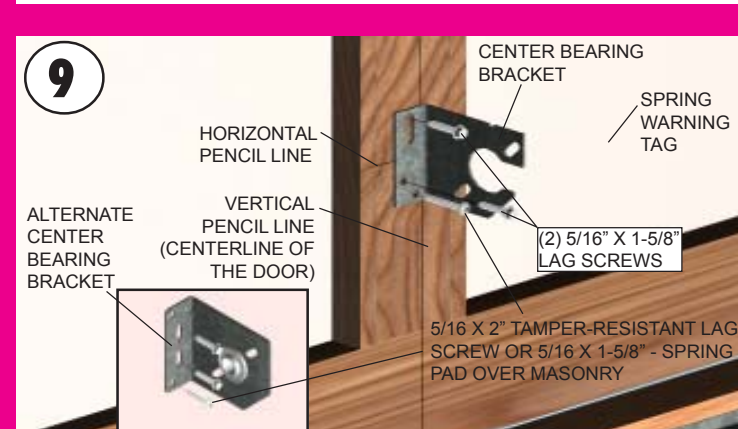

Locate the center of the door and mark a vertical pencil line on the spring pad. Then measure the distance from the center of the mounting hole in the end bearing bracket to the top of the door. Using that same distance, mark a horizontal line on the spring pad, measuring up from the top of the door. Position the center bearing bracket along the vertical pencil line on the spring pad as shown. In addition, position the center bearing bracket halfway over the horizontal pencil line. This will level the torsion tube through the end bearing brackets when installed. Attach the center bearing bracket to the spring pad using (2) 5/16" x 1-5/8" lag bolts and (1) 5/16" x 2" tamper-resistant lag screw.

**IMPORTANT!** Use the 5/16" x 1-5/8" tamper-resistant lag screw ONLY if spring pad is mounted over masonry.

**IMPORTANT!** Tamper-resistant lag screw MUST be attached through the bottom hole of the center bearing bracket.

**WARNING!** FAILURE TO CLAMP TRACK CAN ALLOW DOOR TO RAISE AND CAUSE SEVERE INJURY OR DEATH.

## SCHEDULE A: STRUTS

Door	DOOR WIDTH 8'-0" to 14'-11"	DOOR WIDTH 15'-0" to 18'-0"
Carriage Collection	* (5) 2" ubars	* (5) 3" ubars
Heritage	* (5) 2" ubars	* (5) 3" ubars
Equestrian (3 section)	* (5) 2" ubars	* (5) 3" ubars
Equestrian (4 section)	** (6) 2" ubars	** (6) 3" ubars

**Notes:**  
 \* = (2) Short U-Bar and (3) Long U-Bars with holes  
 \*\* = (2) Short U-Bars and (4) Long U-Bars with holes  
 Short U-Bar = Section width minus 13"  
 Long U-Bar = Section width minus 1"

## SCHEDULE B: STRUT AND HINGE PLACEMENT

**NOTE:** FOR 3 SECTION HIGH MODELS: 7400/7401/7402/7410/7411/7412 SEE MAIN ILLUSTRATION TO THE LEFT.

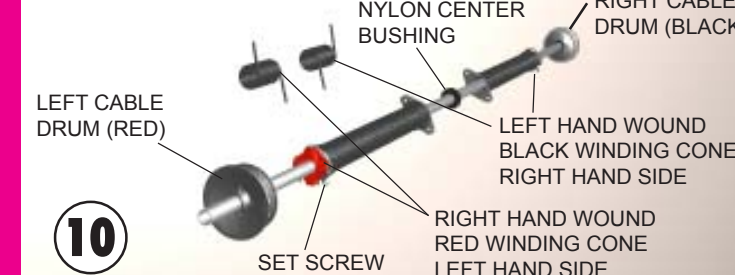
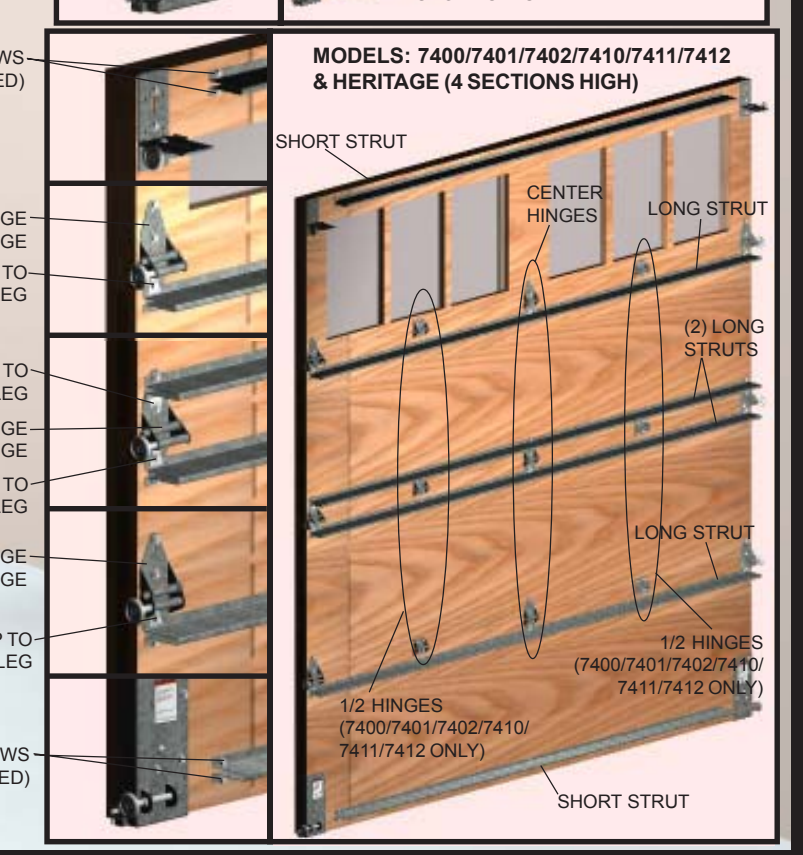
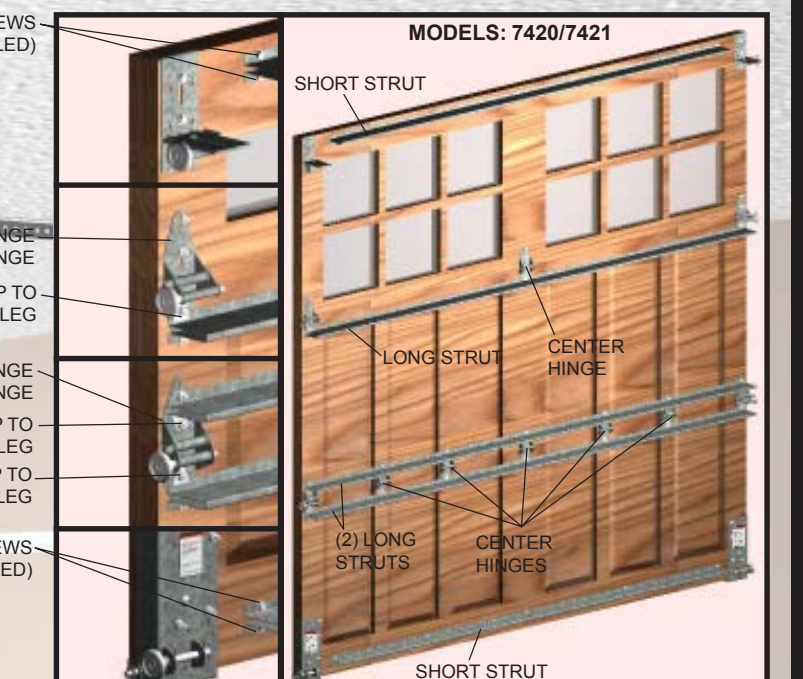

Facing the inside of the door, lay the torsion tube on the floor. Lay the black color coded spring and cable drum on the floor at the right end of the tube. Then lay the red color coded spring and cable drum on the floor at the left end of the tube.

**NOTE:** Right and left hand is always determined from inside the building looking out.

**NOTE:** Some lighter weight doors are provided with only (1) torsion spring. Identify the spring(s) provided as either right hand wound (red winding cone), which goes on the LEFT HAND SIDE or left hand wound (black winding cone), which goes on the RIGHT HAND SIDE.

**NOTE:** The set screws used on all Torsion Counterbalance cable drums and the winding cones are now painted red. DO NOT identify right and left hand side by the set screws.

Slide the nylon center bushing onto the torsion tube followed by the spring(s) and cable drums. The nylon center bushing, spring(s), and cable drums must be positioned as shown in the illustrations. With assistance, pick up the torsion tube assembly and slide one end of the tube through one end bearing bracket. Lay the torsion tube into the center bearing bracket and slide the other end of the tube into the opposite end bearing bracket. Position the torsion tube so that there is an equal amount torsion tube extending from each end bearing bracket.



Slide the nylon center bushing into the end of (1) stationary spring cone and align the cone(s) with the holes in the center bearing bracket. Secure the spring(s) to the center bearing bracket with (2) 3/8-16 x 1-1/2" bolts and nuts.

**NOTE:** Alternate center bearing bracket does not require nylon center bushing.

**IMPORTANT!** Springs under tension can be dangerous. Spring warning tag must be attached to center bearing bracket in obvious sight. If this tag is missing, contact Wayne-Dalton Corp. for free replacements.

**WARNING!** CLAMP LOCKING PLIERS onto both vertical tracks just above the third roller. This is to prevent door from raising while winding the spring(s).



Thread the counterbalance cables around the back side of the cable drums. Before hooking cables into drums, slide the loose cable buttons against the crimped buttons and with a pliers bend a 90 degree angle in the cable as illustrated.

**NOTE:** Some cable assemblies only have the crimped cable button.

Hook the cables into the drums. Slide the left hand cable drum against the end bearing bracket and tighten the set screws in the drum to 14-15 ft-lbs. of torque (Once set screws contact the tube, tighten screws one full turn). Rotate the left hand drum and shaft until cable is taut. Attach locking pliers to shaft and brace pliers against header to keep cable taut. Repeat for the right hand cable drum.

**CAUTION!** Check each cable, making sure both are seated properly on the cable drums and have equal cable tension.

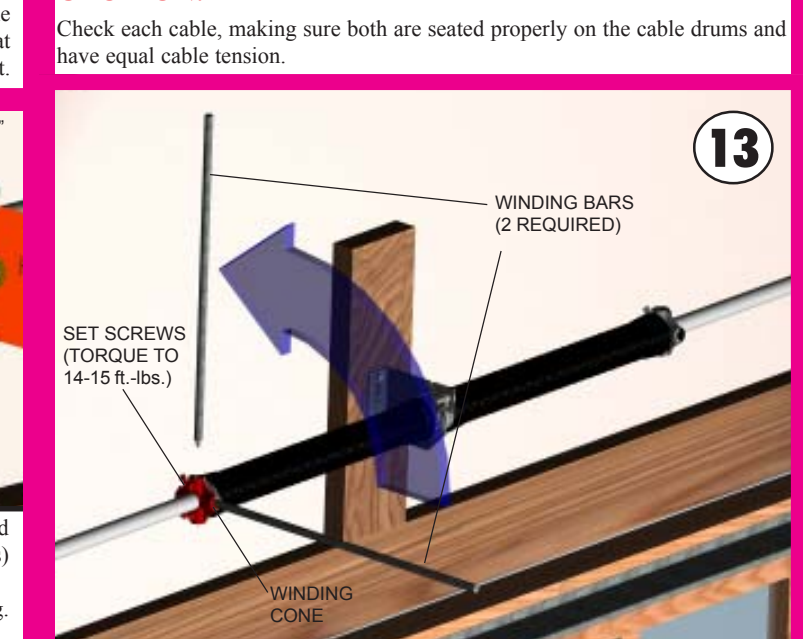

Position a ladder slightly to the side of spring so that the winding cone is easily accessible, yet your body is not in the path of the winding bars. Check the tag(s) attached to the spring(s) for the number of required spring turns. Inserting winding bars into holes of winding cone, one after the other, rotate winding cone upward toward ceiling 1/4 turn at a time until correct number of turns for your door height is achieved. As the last 1/4 turn is achieved, securely hold winding bar while tightening both set screws in winding cone to 14-15 ft-lbs of torque. Carefully remove winding bar from winding cone. If required, repeat for other side.

...Continued on back