

TEXAS DEPARTMENT OF INSURANCE

Engineering Services / MC 103-3A 333 Guadalupe Street P.O. Box 149104 Austin, Texas 78714-9104
Phone No. (512) 322-2212 Fax No. (512) 463-6693

PRODUCT EVALUATION GDR-12

Effective April 1, 2001
Revised December 1, 2003

*The following product has been evaluated for compliance with the wind loads specified in the **International Residential Code (IRC)** and the **International Building Code (IBC)**. This product shall be subject to reevaluation 3 years after the effective date.*

This product evaluation is not an endorsement of this product or a recommendation that this product be used. The Texas Department of Insurance has not authorized the use of any information contained in the product evaluation for advertising, or other commercial or promotional purpose.

This product evaluation is intended for use by those individuals who are following the design wind load criteria in Chapter 3 of the IRC and Section 1609 of the IBC. The design loads determined for the building or structure shall not exceed the design load rating specified for the products shown in the limitations section of this product evaluation. This product evaluation does not relieve a Texas licensed engineer of his responsibilities as outlined in the Texas Insurance Code, the Texas Administrative Code, and the Texas Engineering Practice Act.

WayneMark Series Model 8000 and 8100 Garage Doors, Non-impact and Impact Resistant, as manufactured by:

**Wayne-Dalton Corporation
3395 Addison Drive
Pensacola, Florida 32514
(850) 474-9890**

will be accepted for use in designated catastrophe areas along the Texas Gulf Coast when installed in accordance with this product evaluation. Installation instructions and design drawings, signed by Mark R. Barrow, PE, shall be provided and available on the job site during installation.

PRODUCT DESCRIPTION

The Series Model 8000 and Series Model 8100 are sectional overhead doors constructed from galvanized steel panels with a two-coat baked polyester finish. The doors are 2" thick with box-shaped stiles and tongue and groove sections. The doors are embossed with a woodgrain-textured raised panel design. The Series Model 8000 doors are non-insulated. The Series Model 8100 doors are insulated with $\frac{9}{16}$ " thick expanded polystyrene. The doors are available in widths up to 18'-2".

Product Identification: The door has a warranty/warning label applied during manufacturing that includes the manufacturers name and the Series/Model number for the garage door. The door will also have a second label, applied by the installer that includes the manufacturers name and the design pressure rating for the door.

LIMITATIONS

The doors panels are constructed of 26 GA steel.

The non-impact resistant doors listed in this product evaluation report include glazed panels.

The impact resistant doors listed in this product evaluation report do not include glazed panels.

The maximum width of each door section shall not exceed 21".

The doors shall have a minimum height of 6'-6" and a maximum height of 14'.

The doors utilize horizontal reinforcement. Some doors will utilize 20 GA steel U-bars. Some doors will utilize 16 GA steel C-channels. Some doors will utilize both 20 GA steel U-bars and 16 GA steel C-channels. The type, placement, and installation of the horizontal reinforcement are shown on the design drawings.

Variations in the thickness of the facer steel used and the type of horizontal reinforcement used depends on the Model Option Code number for the doors.

Non-Impact Resistant Doors:

Design drawings: Specified in Table 1 and Table 2

Allowable dimensions: Specified in Table 1

Glazing: Glass is SS ($\frac{3}{32}$ ") annealed monolithic. For 9 foot wide doors, the dimensions of the glass shall not exceed 18" x 12 $\frac{1}{2}$ ". For 16 foot wide doors, the dimensions of the glass shall not exceed 17 $\frac{1}{2}$ " x 11".

Design pressures: Table 2

Impact protection: These doors have not been tested for windborne debris resistance. Doors that contain glazing may not be installed in the Inland I zone without protection from an impact protective system. All doors that are installed in the Seaward zone will need to be protected with an impact protective system.

**Table 1
 Non-Impact Resistant Doors
 Allowable Door Dimensions, Facer Steel Requirements
 and Horizontal Reinforcement Requirements**

Model Option Code (Design Drawings)	Maximum Door Width	Maximum Door Height	Door Panel Steel	Horizontal Reinforcement
0108 Rev: P4; 4 pages	9'-0"	14'-0"	26 GA	20 GA U-bars
0110 Rev: P4; 4 pages	16'-0"	14'-0"	26 GA	20 GA U-bars

**Table 2
 Non-Impact Resistant Doors
 Design Pressure and Height Limitations**

Model Option Code	Design Pressure (psf)
0108	± 29.3
0110	+27, -29

Impact Resistant Doors:

Design drawings: Specified in Table 3 and Table 4

Allowable dimensions: Specified in Table 3

Glazing: Not permitted

Design pressure and height limitations: Table 4

Impact protection: These doors satisfy the Texas Department of Insurance criteria for windborne debris resistance in both the Inland I zone and the Seaward zone. The door assemblies passed Missile Level C specified in ASTM E 1996-99. These doors would not need to be protected with an impact protective system if they are installed in areas where windborne debris protection is required.

Table 3
Impact Resistant Doors
Allowable Door Dimensions, Facer Steel Requirements
and Horizontal Reinforcement Requirements

Model Option Code (Design Drawings)	Maximum Door Width	Maximum Door Height	Door Panel Steel	Horizontal Reinforcement
0119 Rev: P3; 2 pages	9'-0"	14'-0"	26 GA	20 GA U-bars
0120 Rev: P3; 2 pages	9'-0"	14'-0"	26 GA	20 GA U-bars
0121 Rev: P4; 2 pages	16'-2"	14'-0"	26 GA	20 GA U-bars
0122 Rev: P4; 2 pages	16'-2"	14'-0"	26 GA	20 GA U-bar/ 16 GA C channels
0123 Rev: P4; 2 pages	18'-2"	14'-0"	26 GA	16 GA C channels

Table 4
Impact Resistant Doors
Design Pressure and Height Limitations

Model Option Code	Design Pressure (psf)
0119	± 37
0120	+46; -52
0121	+31; -33
0122	+44; -49
0123	+30; -32

INSTALLATION INSTRUCTIONS

Design Drawings: The doors shall be installed as specified on design drawings. The design drawings shall be provided with the door. The following information shall be provided:

Non-impact resistant doors: At the top of the first page, the following information is provided: (1) The Model number (8000 and 8100) and (2) The design pressure rating. At the bottom of each page the following information is provided: (1) The Option Code and (2) The design pressure rating. Each page shall be signed by Mark R. Barrow, PE and dated September 23, 2003.

Impact resistant doors: In the bottom, right corner of each page, there will be a box that contains the following: (1) The Model number (8000 and 8100); (2) The design pressure rating; and (3) The Model Option Code. Each page shall be signed by Mark R. Barrow, PE and dated September 23, 2003.

Attachment of Doors to Wall (Use One of the Following Four Methods):

Direct Attachment of Door Components to Concrete/Masonry Block Walls: Brackets for the vertical tracks and for the flag angles of the door shall be attached directly to the concrete/masonry block wall with the fasteners specified on the design drawings.

Attachment of Door Components to Wood-Framed Walls Using a Wood Jamb: Brackets for the vertical tracks and for the flag angles of the door shall be attached directly to wood jambs with the fasteners specified on the design drawings. The wood jambs shall be minimum 2x6 SYP lumber. The attachment of the 2x6 wood jambs to the wood-framed walls shall be as specified in Tables 5, 6, and 7.

Direct Attachment of Door Components to Wood-Framed Walls: Brackets for the vertical tracks and for the flag angles of the door shall be attached directly to the wall framing with the fasteners specified on the design drawings. The attachment of the vertical tracks shall be as shown in Figures 1 and 2.

Attachment of Door Components to Concrete/Masonry Block Walls Using a Wood Jamb: Brackets for the vertical tracks and for the flag angles of the door shall be attached directly to wood jambs with the fasteners specified on the design drawings. The wood jambs shall be minimum 2x6 SYP lumber. The attachment of the 2x6 wood jambs to the concrete/masonry block wall shall be as specified in Table 8 or Table 9.

Table 5
Attachment of 2x6 Wood Jambs to Southern Yellow Pine Wood Wall Framing
(Fastener: $\frac{3}{8}$ " Diameter Lag Screws)
(Maximum Fastener Spacing Per Jamb (in inches))

Door Height	Model Option Code						
	0108	0110	0119	0120	0121	0122	0123
6'-6" to 14'	51	40	44	40	37	31	36

1. Minimum thread embedment depth into wood framing of $2\frac{1}{2}$ ".
2. Provide the quantity of lag screws required to maintain maximum spacing with a minimum of three (3) lag screws per jamb.
3. A lag screw shall be located a maximum distance of 6" from each end of each jamb.
4. Minimum distance from any edge of wood (jamb or wall framing) shall be $1\frac{1}{2}$ ".

Table 6
 Attachment of 2x6 Wood Jamb to Douglas Fir-Larch Wood Wall Framing
 (Fastener: $\frac{3}{8}$ " Diameter Lag Screws)
 (Maximum Fastener Spacing Per Jamb (in inches))

Door Height	Model Option Code						
	0108	0110	0119	0120	0121	0122	0123
6'-6" to 14'	47	38	42	38	35	28	33

1. Minimum thread embedment depth into wood framing of $2\frac{1}{2}$ ".
2. Provide the quantity of lag screws required to maintain maximum spacing with a minimum of three (3) lag screws per jamb.
3. A lag screw shall be located a maximum distance of 6" from each end of each jamb.
4. Minimum distance from any edge of wood (jamb or wall framing) shall be $1\frac{1}{2}$ ".

Table 7
 Attachment of 2x6 Wood Jamb to Spruce-Pine-Fir Wood Wall Framing
 (Fastener: $\frac{3}{8}$ " Diameter Lag Screws)
 (Maximum Fastener Spacing Per Jamb (in inches))

Door Height	Model Option Code						
	0108	0110	0119	0120	0121	0122	0123
6'-6" to 14'	48	38	42	38	34	25	32

1. Minimum thread embedment depth into wood framing of $2\frac{1}{2}$ ".
2. Provide the quantity of lag screws required to maintain maximum spacing with a minimum of three (3) lag screws per jamb.
3. A lag screw shall be located a maximum distance of 6" from each end of each jamb.
4. Minimum distance from any edge of wood (jamb or wall framing) shall be $1\frac{1}{2}$ ".

Table 8
 Attachment of 2x6 Wood Jamb to Concrete/Masonry Block Wall
 (Fastener: $\frac{3}{8}$ " Diameter Simpson Strong-Tie Wedge-All)
 (Maximum Fastener Spacing Per Jamb (in inches))

Door Height	Model Option Code						
	0108	0110	0119	0120	0121	0122	0123
6'-6" to 14'	47	30	37	30	25	18	24

1. Based on minimum 2000 psi concrete.
2. Minimum embedment depth of $2\frac{5}{8}$ " into concrete.
3. Minimum distance from edge of concrete is 3"
4. Based on minimum 2000 psi grout-filled CMU.
5. Minimum embedment depth of 3" into grout-filled CMU.
6. Minimum distance from edge and end of grout-filled CMU is 4"
7. CMU shall conform to ASTM C90 and the grout shall conform to ASTM C476.
8. Provide the quantity of wedge anchors required to maintain maximum spacing with a minimum of three (3) wedge anchors per jamb.
9. A wedge anchor shall be located a maximum distance of 6" from each end of each jamb.
10. Minimum distance from any edge of wood jamb shall be $1\frac{1}{2}$ ".

Table 9
Attachment of 2x6 Wood Jamb to Concrete Wall
(Fastener: $\frac{3}{8}$ " Diameter L Bolt)
(Maximum Fastener Spacing Per Jamb (in inches))

Door Height	Model Option Code						
	0108	0110	0119	0120	0121	0122	0123
6'-6" to 14'	47	36	42	36	31	22	28

1. Based on minimum 2000 psi concrete.
2. Minimum embedment depth of 3" into concrete.
3. Minimum distance from edge of concrete is 3"
4. Provide the quantity of anchor bolts required to maintain maximum spacing with a minimum of three (3) anchor bolts per jamb.
5. An anchor bolt shall be located a maximum distance of 6" from each end of each jamb.
6. Minimum distance from any edge of wood jamb shall be $1\frac{1}{2}$ ".

Note: The manufacturer's installation instructions and the appropriate Model Option Code design drawings, signed by Mark R. Barrow, PE, shall be available on the job site during installation. All fasteners shall be corrosion resistant as specified in the International Residential Code (IRC) and the International Building Code (IBC).

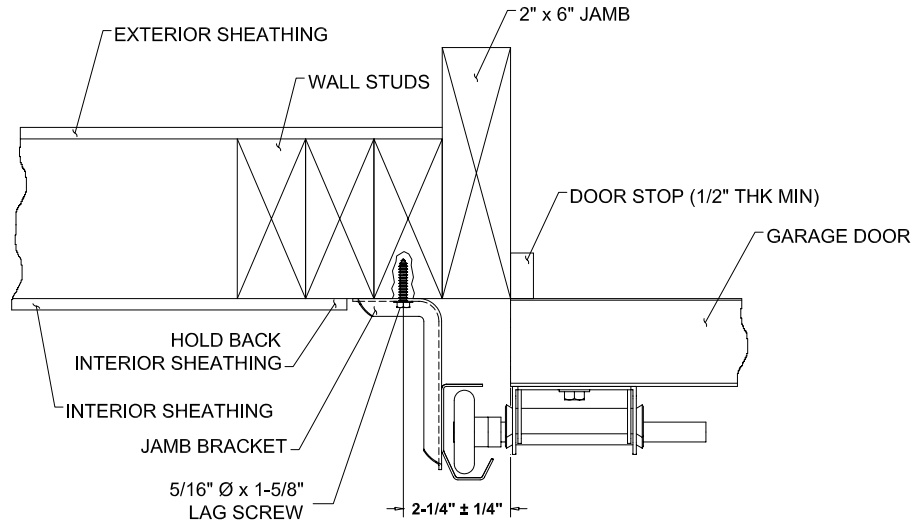

Figure 1: Attachment of Garage Door Brackets Directly to Wood Wall Framing (Option 1)

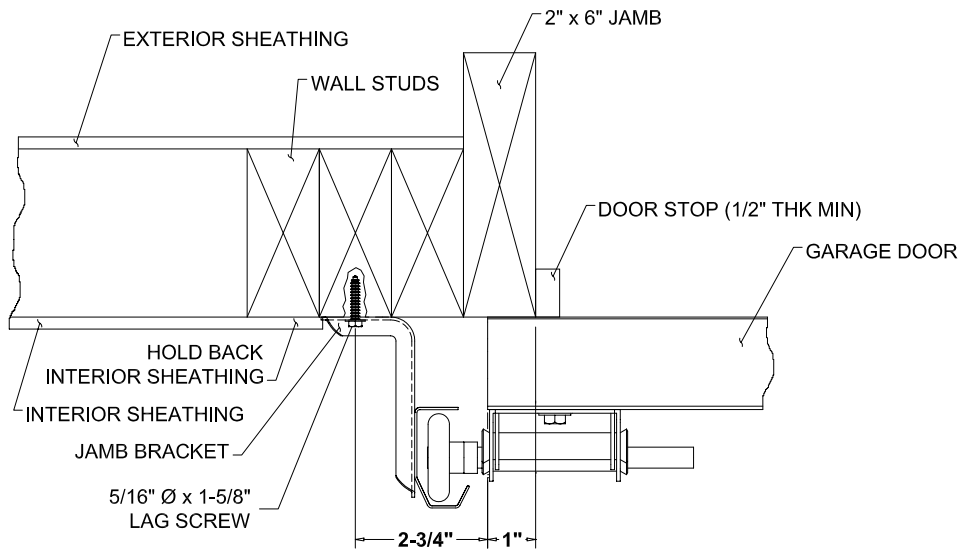

Figure 2: Attachment of Garage Door Brackets Directly to Wood Wall Framing (Option 2)