

START HERE

IMPORTANT! READ IMPORTANT SAFETY NOTICES AND REFER TO INSERT SHEET INSTRUCTIONS TITLED "REMOVING THE OLD DOOR/ PREPARING THE OPENING". IF THE INSERT SHEET INSTRUCTIONS ARE NOT INCLUDED, CONTACT WAYNE-DALTON CORP. FOR A FREE COPY.

If removing an existing door, carefully follow the directions given on the insert sheet instruction in the portion titled "Removing the Old Door".

WARNING! REMOVAL OF AN EXISTING DOOR CAN BE DANGEROUS. FOLLOW INSERT SHEET INSTRUCTIONS CAREFULLY, OTHERWISE SERIOUS INJURY OR DEATH COULD RESULT.

Begin the installation of the door by checking the opening. It must be the same size as the door. Vertical jamba must be plumb and the header level. Side clearance, from edge of door to wall, must be minimum of 3-1/2" (89 mm) on each side. For proper opening preparation refer to the portion of the insert sheet instructions titled "Preparing the Opening".

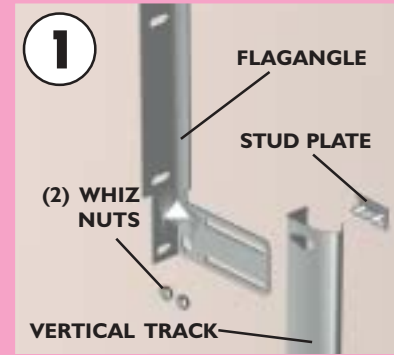

Secure the vertical track to the lower slot in the flagangle using (1) stud plate and (2) whiz nuts.

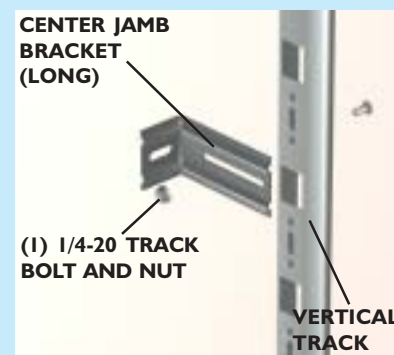

To attach the bottom (short) jamb bracket, locate the lower hole/slot pattern of the vertical track. Align the slot in the jamb bracket with the lower hole of the hole/slot pattern in the vertical track. Secure jamb bracket, using (1) 1/4-20 x 9/16" track bolt and nut. Place the center (long) jamb bracket over the hole/slot pattern nearest to the center of the track. Loosely fasten the bracket onto the track with (1) 1/4-20 x 9/16" track bolt and nut.

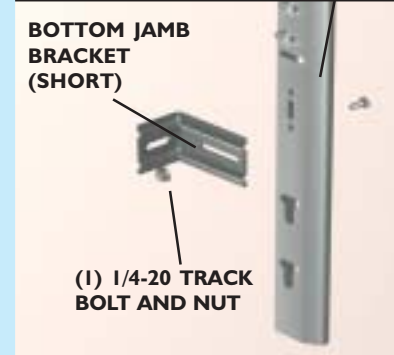

NOTE: Doors over 7'3" high get (3) sets of jamb brackets. Install the center and top jamb brackets so that they are equally spaced in between the flagangle and bottom jamb bracket.

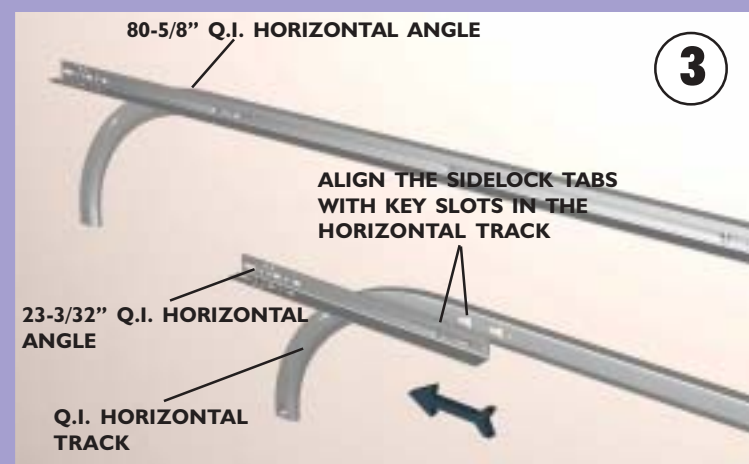

Align the SlideLock™ tabs on the applicable Q.I. horizontal angle with key slots in the Q.I. horizontal track as shown. Push the parts together. Using a hammer, tap the Q.I. horizontal angle towards the curved end of the track until the hole(s) in track and angle are aligned. Set track aside.

NOTE: For larger size doors, a full length horizontal angle is already spot welded to the horizontal track.

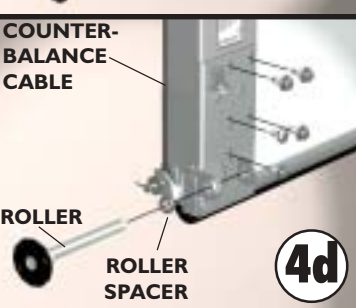
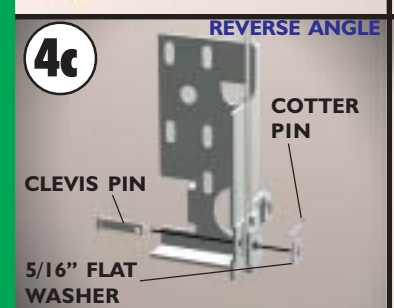
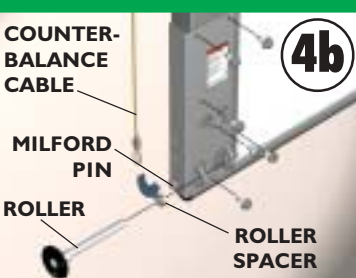
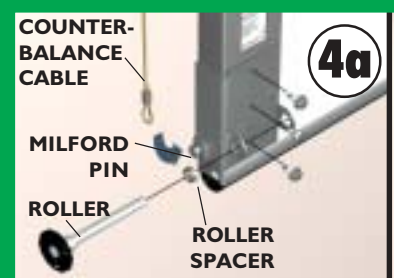

Bottom brackets are right and left. Before attaching the bottom brackets, secure the counterbalance cables to the brackets by placing the looped end of the cables over the milford pin (see Fig. 4a and Fig. 4b), or using a clevis pin, washer and cotter pin (see Fig. 4c). Attach the bottom brackets to the bottom corners of section using (2) 1/4-20 x 11/16" self drilling screws and (1) tamper-resistant self drilling screw for 8300 doors (Fig. 4a), (5) 1/4-20 x 11/16" self drilling screws and (1) tamper-resistant self drilling screw for 8300 doors greater than 16 ft. wide (Fig. 4b), and (4) 1/4-20 x 11/16" self drilling screws and (1) tamper-resistant self drilling screw for 8500 doors (see Fig. 4d).

IMPORTANT! Right and left hand is always determined from inside the building looking out.

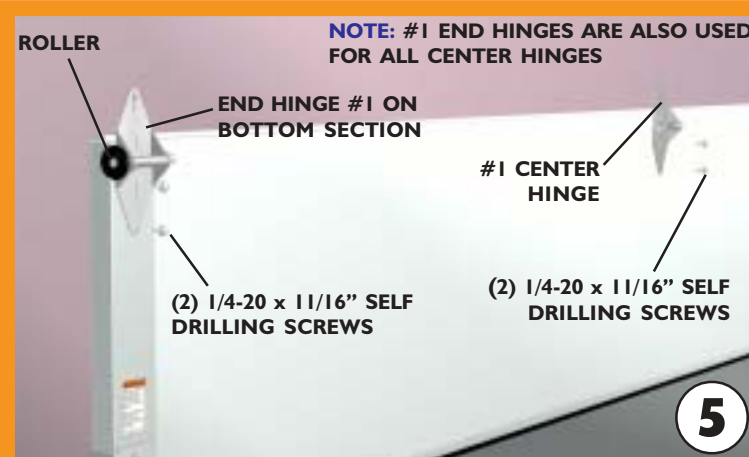

NOTE: #1 END HINGES ARE ALSO USED FOR ALL CENTER HINGES

Align the lower (numbered) leaf of the #1 end hinges and required #1 center hinges over the holes in the endcaps, and the dimples, in the middle at the top of the bottom section. Secure the hinges to the section using (2) 1/4-20 x 11/16" self drilling screws each. Repeat for all other sections using the #2 end hinges on the second or lock section and the #3 end hinges on the third section.

NOTE: #4 End hinges are used on fourth section of five section doors.

NOTE: Bottom section can be identified by the factory attached bottom astragal and by the bottom bracket warning labels on each endcap.

IMPORTANT! When placing rollers into end hinges number 2 and higher, the roller goes into tube furthest away from section.

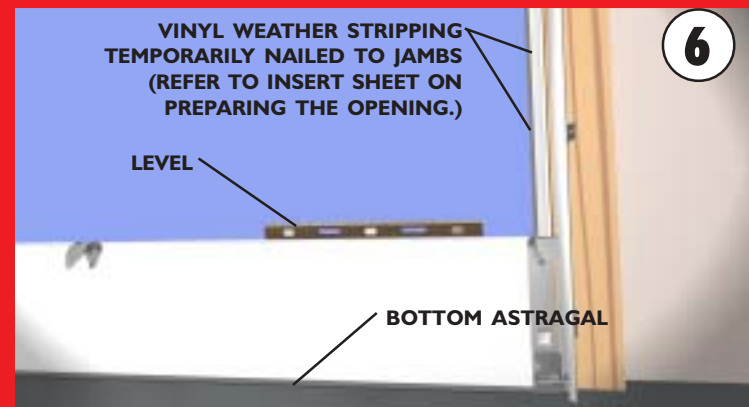

Before installing the bottom section, measure and cut vinyl jamb weather-stripping (not included) for entire garage door opening. Vinyl weather seal must be installed prior to door installation. Attach the weather seal to the door jamb 1/8" to 1/4" past door jamb (see figure below). Temporarily nail the weather-stripping to the door jamba and header. This will help hold the bottom door section in place. Refer to the insert sheet on preparing the opening.

Now comes the single most important step in installing the Wayne-Dalton garage door system. Center the bottom section in the door opening. Level it using wooden shims under the bottom astragal as needed. Once the bottom section is level, all the other components will automatically align. Hold the section in the opening while attaching vertical tracks.

NOTE: In the event that the bottom section was shimmed to level it, then the vertical track on that same side of the section must be raised the thickness of the shim(s). The tops of the vertical track must be level.

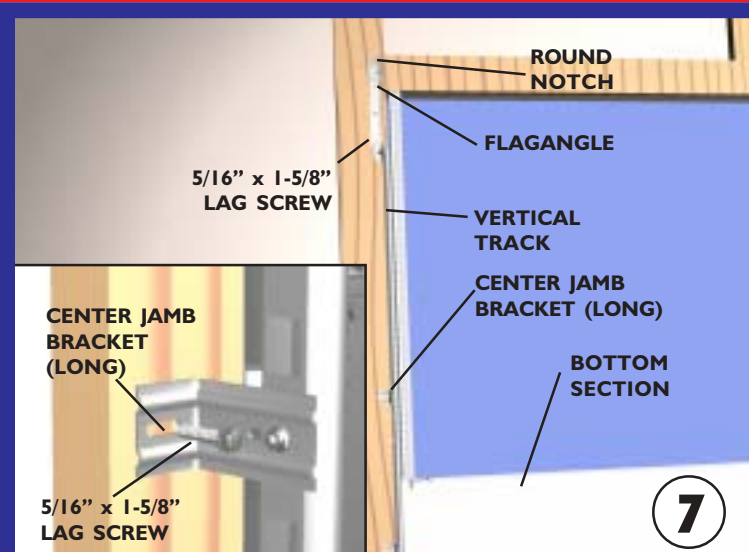

Position the vertical track over the rollers of the bottom section. Make sure the counterbalance cable is located between the rollers and the door jamb. Loosely fasten bottom jamb bracket and flagangle with (1) 5/16" x 1-5/8" lag screw each, but do not install a lag screw into the center jamb bracket yet. Run the counterbalance cable up between vertical track and edge of door section. Hang the counterbalance cable over the top of the flagangle in round notch. Repeat for other side.

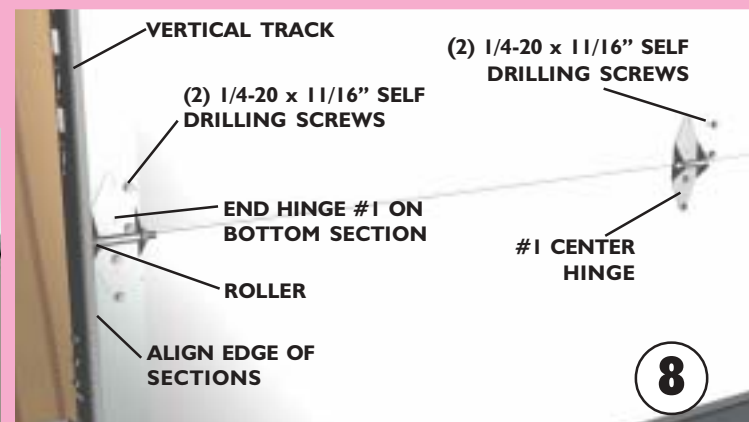

Make sure top leaves of all hinges on the bottom section are folded down. Insert rollers into the end hinges of the second section (also referred to as lock section). With assistance lift section and place rollers over the tops of the vertical tracks. Install by guiding rollers into the vertical track on both sides and gently lowering this section onto the bottom section. Keeping the ends of the sections aligned, install remaining section(s), except top section, in same manner. Fasten all rollers to connect the sections by flipping up the hinge leaf, holding it firmly against section and driving in the supplied 1/4-20 x 11/16" torque limiting screws.

NOTE: To install lock, see lock instructions included in the lock assembly bag.

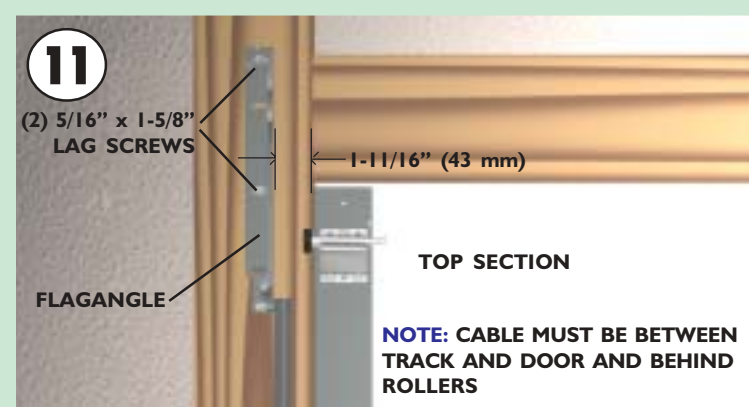
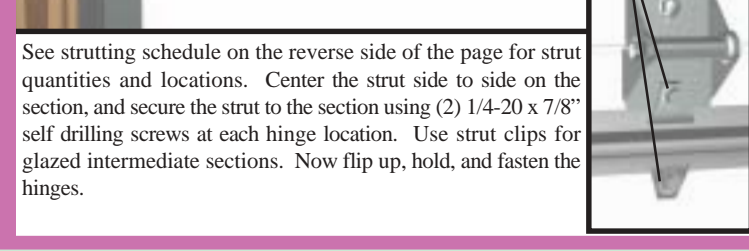
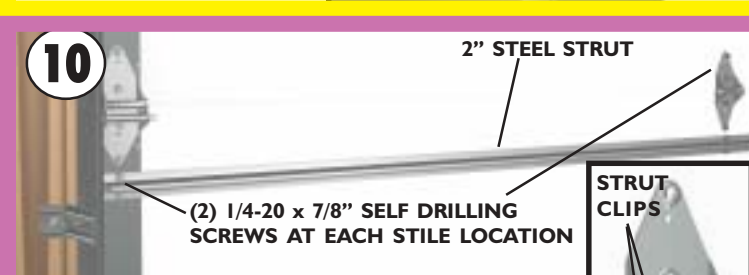
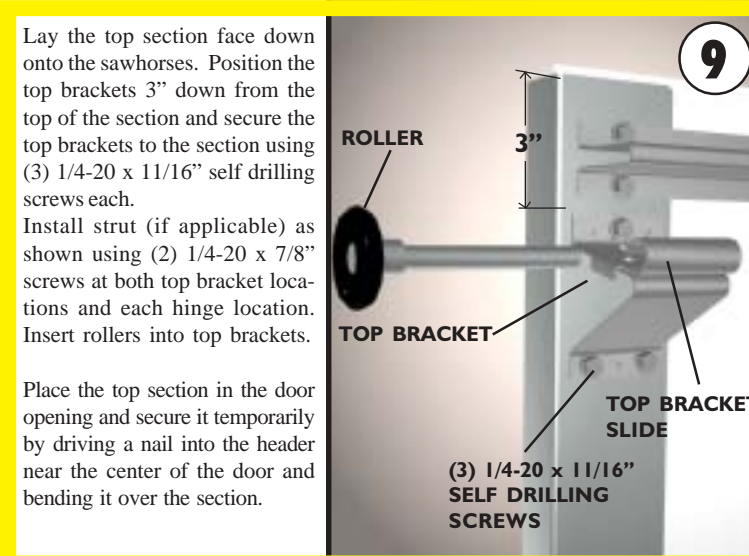

Position flagangle 1-11/16" (43 mm) from the edge of the door. Tighten the first lag screw then secure flagangle to the jamb with 2 more 5/16" x 1-5/8" lag screws. Now complete the vertical track installation on both sides by securing the center jamb brackets and tightening other lag screws.

IMPORTANT! Vertical tracks must be secured so that the rollers are touching the deepest part of the curved side of the track.

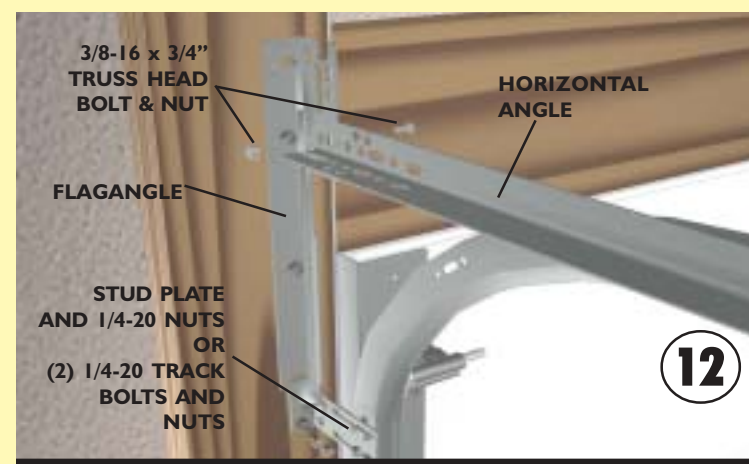

To install horizontal track, place the curved end over the top roller. Align the bottom of the horizontal track with the top of vertical track. Secure the track to the flagangle with (1) stud plate and nuts. Level horizontal track and bolt the horizontal angle to the side in the flagangle using (1) 3/8-16 x 3/4" truss head bolt and nut. Repeat for other side. Remove nail which is temporarily holding the top section.

With tracks installed you can adjust the top brackets. Vertically align the top section with the lower sections. Once aligned, position top roller in adjustable slide against horizontal track to maintain position and tighten nut(s). Repeat for other side.

NOTE: For "bolt on" track, secure the horizontal track to the flagangle with (2) 1/4-20 track bolts and nuts

IMPORTANT! Failure to remove nail before attempting to raise door could cause permanent damage to top section.

WARNING! DO NOT ATTEMPT TO RAISE DOOR AT THIS TIME.

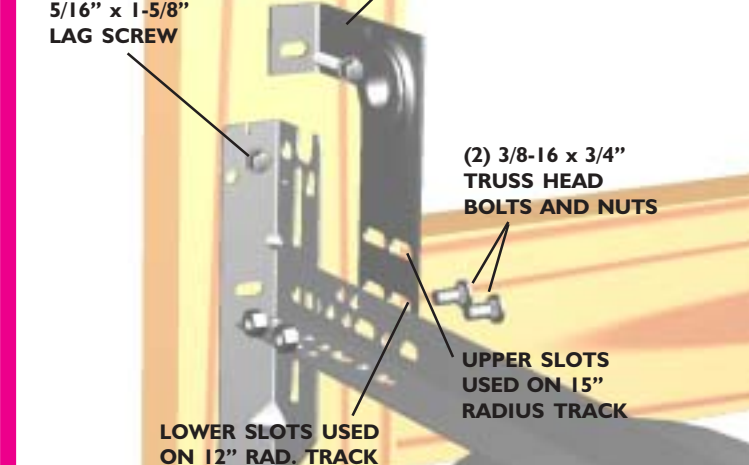

Locate the end bearing bracket above the flagangle and secure the bracket to the horizontal angle using (2) 3/8-16 x 3/4" truss head bolts and nuts. Once the bracket is secured to the horizontal angle, secure the top of the bracket to the jamb using (1) 5/16" x 1-5/8" lag bolt.

NOTE: End bearing brackets must be attached through the lower slots on 12" radius track and through the upper slots on 15" radius track.

IMPORTANT! DOOR OPENING PREPARATION IS CRITICAL FOR PROPER DOOR INSTALLATION. REFER TO INSERT SHEET "PREPARING THE OPENING" BEFORE INSTALLING NEW DOOR.

IMPORTANT! JAMBS, HEADER AND SPRING PAD MUST BE SECURELY ATTACHED TO FRAMING MEMBERS. CHECK BEFORE INSTALLING NEW DOOR.

IMPORTANT! REAR SUPPORT ASSEMBLIES MUST BE SECURELY ATTACHED TO CEILING FRAMING MEMBERS ADEQUATE TO HOLD THE WEIGHT OF THE DOOR.

IMPORTANT! IF INSTALLING A REPLACEMENT DOOR, CHECK THE OPENING SIZE AND NEW DOOR SIZE, MAKING SURE THEY MATCH BEFORE REMOVING EXISTING DOOR.

NOTE: SINGLE WIDE DOOR SHOWN IN ILLUSTRATION. (STRUTS NOT SUPPLIED ON SINGLE WIDE DOORS)

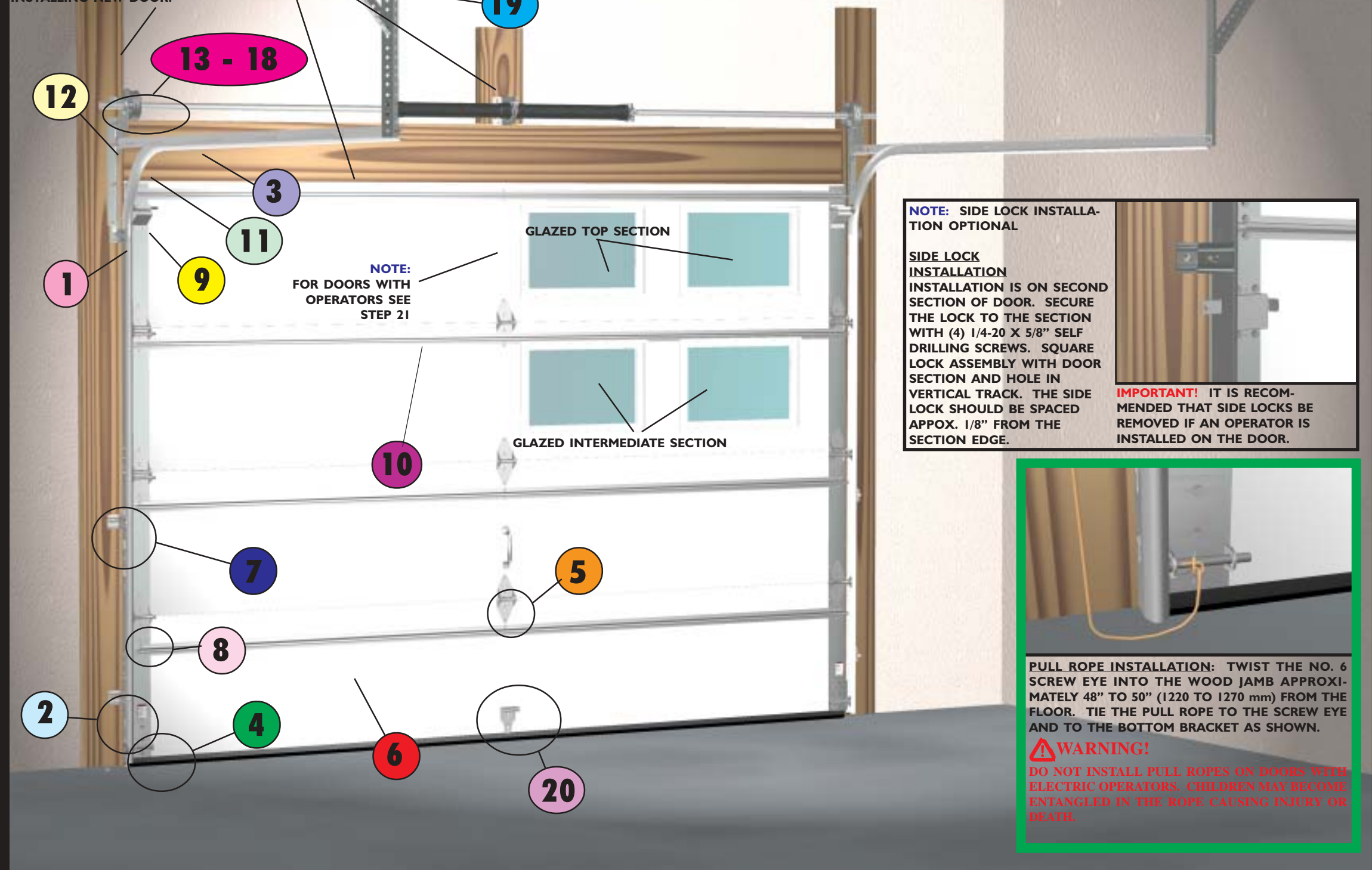

NOTE: SIDE LOCK INSTALLATION OPTIONAL

SIDE LOCK INSTALLATION IS ON SECOND SECTION OF DOOR. SECURE THE LOCK TO THE SECTION WITH (4) 1/4-20 X 5/8" SELF DRILLING SCREWS. SQUARE LOCK ASSEMBLY WITH DOOR SECTION AND HOLE IN VERTICAL TRACK. THE SIDE LOCK SHOULD BE SPACED APPROX. 1/8" FROM THE SECTION EDGE.

IMPORTANT! IT IS RECOMMENDED THAT SIDE LOCKS BE REMOVED IF AN OPERATOR IS INSTALLED ON THE DOOR.



PULL ROPE INSTALLATION: TWIST THE NO. 6 SCREW EYE INTO THE WOOD JAMB APPROXIMATELY 48" TO 50" (1220 TO 1270 mm) FROM THE FLOOR. TIE THE PULL ROPE TO THE SCREW EYE AND TO THE BOTTOM BRACKET AS SHOWN.

WARNING! DO NOT INSTALL PULL ROPES ON DOORS WITH ELECTRIC OPERATORS. CHILDREN MAY BECOME ENTANGLED IN THE ROPE CAUSING INJURY OR DEATH.

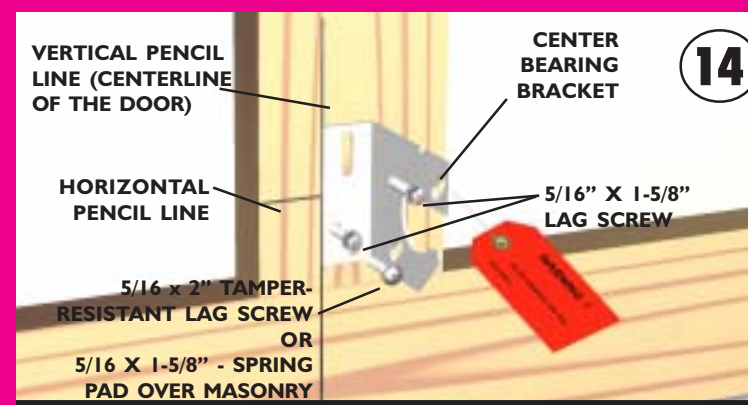

Locate the center of the door and mark a vertical pencil line on the spring pad. Then measure the distance from the center of the mounting hole (hole where tube fits into) in the end bearing bracket to the top of the door. Using that same distance, mark a horizontal line on the spring pad, measuring up from the top of the door. Align the center bearing bracket edge along the vertical pencil line on the spring pad as shown. In addition, position the center bearing bracket halfway over the horizontal pencil line. This will level the torsion tube through the end bearing brackets when installed. Attach the center bearing bracket to the spring pad using (2) 5/16" x 1-5/8" lag screws and (1) 5/16" x 2" tamper-resistant lag screw.

IMPORTANT! Use the 5/16" x 1-5/8" tamper-resistant lag screws ONLY if spring pad is mounted over masonry.

IMPORTANT! Tamper-resistant lag screws MUST be attached through the bottom hole of the center bearing bracket.

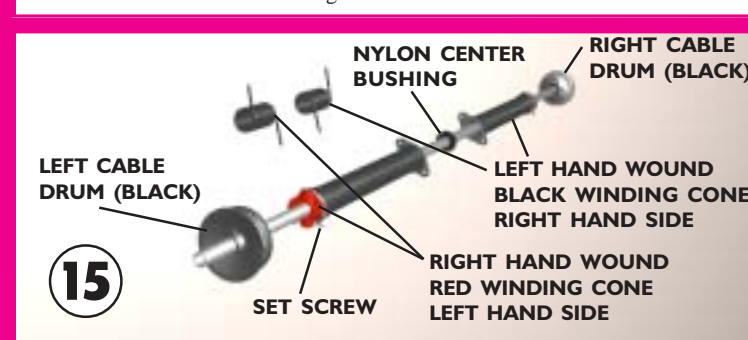

Facing the inside of the door, lay the torsion tube on the floor. Lay the black color coded winding cone with spring and cable drum on the floor at the right end of the tube. Then lay the red color coded winding cone with spring and cable drum on the floor at the left end of the tube.

NOTE: Right and left hand is always determined from inside the building looking out.

NOTE: Some lighter weight doors are provided with only (1) torsion spring. Identify the spring(s) provided as either right hand wound (red winding cone), which goes on the LEFT HAND SIDE or left hand wound (black winding cone), which goes on the RIGHT HAND SIDE.

NOTE: The set screws used on all Torsion Counterbalance cable drums and winding cones are now painted red. DO NOT identify right and left hand side by the set screws.

Slide the nylon center bushing onto the torsion tube followed by the spring(s) and cable drums. The nylon center bushing, spring(s), and cable drums must be positioned as shown in the illustrations. With assistance, pick up the torsion tube assembly and slide one end of the tube through one end bearing bracket. Lay the torsion tube into the center bearing bracket and slide the other end of the tube into the opposite end bearing bracket. Position the torsion tube so that equal amounts of the tube extend from each end bearing bracket.

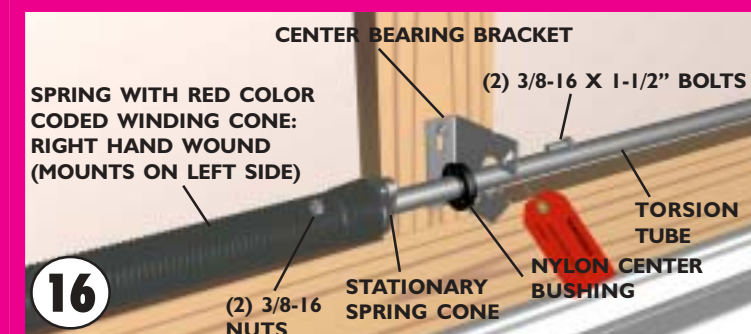

Slide the nylon center bushing into the end of (1) stationary spring cone and align the cone(s) with the holes in the center bearing bracket. Secure the spring(s) to the center bearing bracket with (2) 3/8-16 x 1-1/2" bolts and nuts.

IMPORTANT! Springs under tension can be dangerous. Spring warning tag must be attached to center bearing bracket in obvious sight. If this tag is missing, contact Wayne-Dalton Corp. for free replacements.

Clamp locking pliers onto both vertical tracks just above the third roller. This is to prevent door from raising while winding the spring(s).

WARNING! FAILURE TO CLAMP TRACK CAN ALLOW DOOR TO RAISE AND CAUSE SEVERE INJURY OR DEATH.

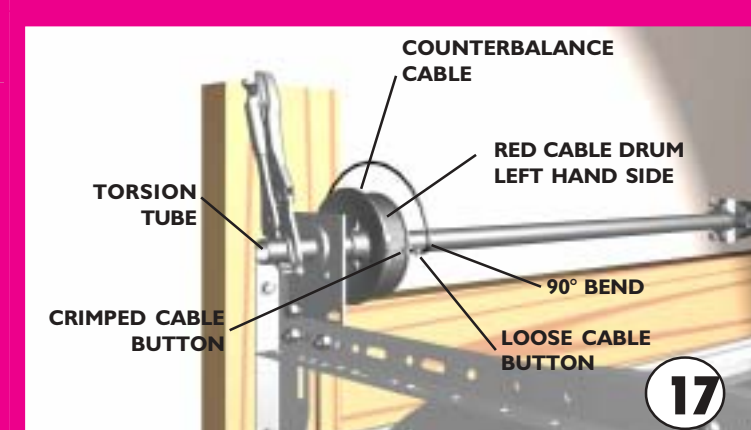

Thread the counterbalance cables around the back side of the cable drums and verify that there is no cable obstructions. Before hooking cables into drums, slide the loose cable buttons against the crimped buttons and with a pliers bend a 90 degree angle in the cable as illustrated.

NOTE: Some cable assemblies only have the crimped cable button.

Hook the cables into the drums. Slide the left hand cable drum against the end bearing bracket and tighten the set screws in the drum to 14-15 ft. lbs. of torque (Once set screws contact the tube, tighten screws one full turn). Rotate the left hand drum and torsion tube until cable is taut. Attach locking pliers to torsion tube and brace locking pliers against jamb to keep cable taut. Slide the right hand cable drum against the end bearing bracket and rotate drum until cable is taut. Tighten set screws in right hand cable drum.

CAUTION! Check each cable, making sure both are seated properly on the cable drums and have equal cable tension.

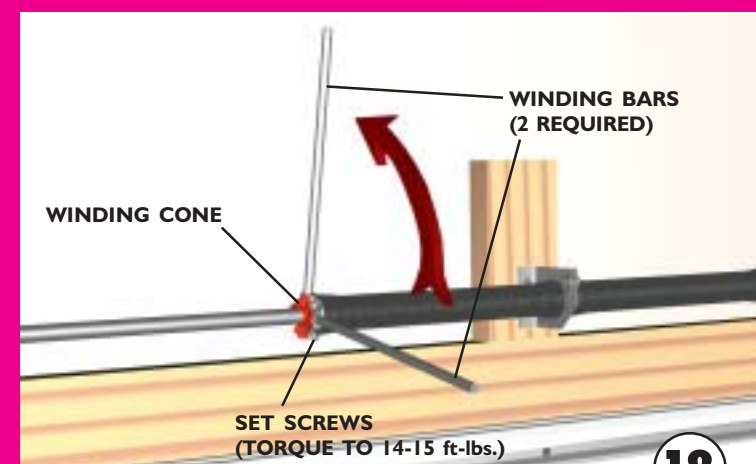

Position a ladder slightly to the side of spring so that the winding cone is easily accessible, yet your body is not in the path of the winding bars. Check the tag(s) attached to the spring(s) for the number of required spring turns.

6'0" Door Height	=	Approx. 6-3/4 Turns
6'3" Door Height	=	Approx. 7 Turns
6'6" Door Height	=	Approx. 7-1/4 Turns
6'9" Door Height	=	Approx. 7-1/2 Turns
7'0" Door Height	=	Approx. 7-1/2 Turns
7'3" Door Height	=	Approx. 8 Turns
7'6" Door Height	=	Approx. 8-1/4 Turns
7'9" Door Height	=	Approx. 8-1/2 Turns
8'0" Door Height	=	Approx. 8-1/2 Turns

Inserting winding bars into holes of winding cone, one after the other, rotate winding cone upward toward ceiling 1/4 turn at a time until correct number of turns for your door height is achieved. As the last 1/4 turn is achieved, securely hold winding bar while tightening both set screws in winding cone to 14-15 ft. lbs. of torque (Once set screws contact the tube, tighten screws one full turn). Carefully remove winding bar from winding cone. If required, repeat for other side.

While holding the door down to prevent it from rising unexpectedly, in the event the spring(s) were overwound. Carefully remove the locking pliers from the vertical tracks and torsion tube. Raise the door until the top section and half of the next section are in a horizontal position. Do not raise door any further since rear of horizontal track is not yet supported.

WARNING! RAISING DOOR FURTHER CAN RESULT IN DOOR FALLING AND CAUSE SEVERE INJURY OR DEATH.

Now clamp a pair of locking pliers to the vertical tracks just above the second roller on one side, and just below the second roller on the other side. This will prevent the door from raising or lowering while installing the rear support.

